



**THE DATASHEET OF
KTD2027EWE-TR**



Constant Current RGB/White LED Driver with I²C Control

Features

- Ultra low dropout regulated current sinks
 - ▶ 3-Channels: KTD2026
 - ▶ 4-Channels: KTD2027
- 40mV typical at 10mA per channel
- Programmable LED setting using I²C control
- Individual channel control
 - ▶ On/Off Interval Time Control
 - ▶ Dimming Up/Down Time
 - ▶ Current Level Setting
 - ▶ RGB or RGBW LED Color Control
- 192 current levels: 24mA max, 0.125mA step
- ±5% current matching for max current
- Low supply current of 200µA typ.
- No noise, non-pulsating LED current
- Fast, smooth start-up
- V_{IN} Range: 2.7V to 5.5V
- 0.1µA Shutdown Current
- Pb-free Package: UTDFN-8 1.5x1.5mm
- RoHS and Green Compliant
- -40°C to +85°C Temperature Range

Applications

- RGB indicator LEDs
- Flashing LEDs
- Mobile Phones
- Handheld Devices
- Digital Cameras

Typical Application

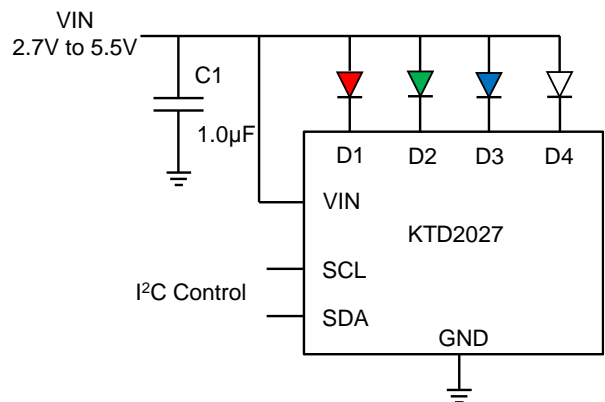
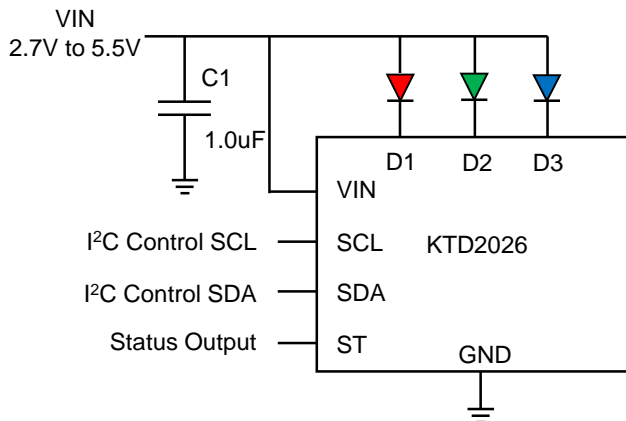

Brief Description

The KTD2026/7 are fully programmable, constant current RGB or RGBW LED drivers with a flexible control interface. The devices are ideally powered from one-cell lithium-ion/polymer, 3-cell NiCd/NiMH/Alkaline batteries, or systems with 3.3V or 5V supplies. The independent programmable constant current sinks operate without external components.

With an on-chip timing control unit, LED blink rate, fade-in and fade-out are user-adjustable resulting in unique color lighting patterns.

Ten internal registers are programmed via the I²C interface with a built-in decoder allowing individual control of the three/four LED channels' On/Off state and current level. A total of 192 current levels are available for each channel from 0.125mA to 24mA with a 0.125mA step.

In shutdown mode, the quiescent current is reduced to less than 1µA.

The driver is available in a low profile 8-pin 1.5mm x 1.5mm x 0.5mm Ultra-Thin DFN package. The packages are Pb-free, RoHS and Green compliant.

Pin Descriptions

UTDFN 1.5x1.5, 8-pin Package

Pin #		Name	Function
KTD2026	KTD2027		
1	--	ST	Status open-drain logic output stays low (on state) during first half of the flash period (50% duty cycle) then goes to high-impedance (off) during second half of the flash period. An optional pull-up resistor can be connected from this pin to the supply.
--	1	D4	Regulated output current sink D4. Current level and ON/OFF selections are controlled by serial interface.
2	2	D3	Regulated output current sink D3. Current level and ON/OFF selections are controlled by serial interface.
3	3	D2	Regulated output current sink D2. Current level and ON/OFF selections are controlled by serial interface.
4	4	D1	Regulated output current sink D1. Current level and ON/OFF selections are controlled by serial interface.
5	5	VIN	Input power for the IC.
6	6	SCL	Clock of the I ² C interface.
7	7	SDA	Data of the I ² C interface.
8	8	GND	Ground pin.

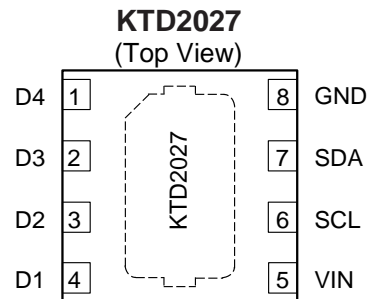
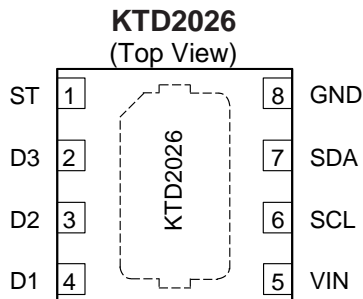

Absolute Maximum Ratings¹

(T_A = 25°C unless otherwise noted)

Symbol	Description	Value	Units
V _{IN} , D2, D3, D4, ST	Input voltage, Output pins	-0.3 to 6.0	V
SCL, SDA, D1	Control Interface pins and D1 sink pin	-0.3 to V _{IN} +0.3	V
T _J	Operating Temperature Range	-40 to 150	°C
T _s	Storage Temperature Range	-65 to 150	°C
T _{LEAD}	Maximum Soldering Temperature (at leads, 10 sec)	300	°C
ESD	HBM electrical static discharge	2.0	kV

Thermal Capabilities

Symbol	Description	Value	Units
UTDFN1.5x1.5-8			
θ _{JA}	Thermal Resistance – Junction to Ambient ²	190	°C/W
P _D	Maximum Power Dissipation at T _A ≤ 25°C	0.526	W
ΔP _D /°C	Derating Factor Above T _A = 25°C	-5.26	mW/°C

Ordering Information

Part Number	IOUT max Per channel	I ² C Device Address	Marking ³	Operating Temperature	Package
KTD2026EWE-TR	24mA	30h	ETYYZ	-40°C to +85°C	UTDFN1.5x1.5-8
KTD2026BEWE-TR	24mA	31h	GKYYZ	-40°C to +85°C	UTDFN1.5x1.5-8
KTD2026CEWE-TR	24mA	32h	LYYYZ	-40°C to +85°C	UTDFN1.5x1.5-8
KTD2027EWE-TR	24mA	30h	ESYYZ	-40°C to +85°C	UTDFN1.5x1.5-8
KTD2027BEWE-TR	24mA	31h	LZYYZ	-40°C to +85°C	UTDFN1.5x1.5-8

1. Stresses above those listed in Absolute Maximum Ratings may cause permanent damage to the device. Functional operation at conditions other than the operating conditions specified is not implied. Only one Absolute Maximum rating should be applied at any one time.

2. Junction to Ambient thermal resistance is highly dependent on PCB layout. Values are based on thermal properties of the device when soldered to an EV board.

3. "YYZ" is the date code and assembly code.

Electrical Characteristics⁴

Unless otherwise noted, the *Min* and *Max* specs are applied over the full operation temperature range of -40°C to +85°C, while *Typ* values are specified at room temperature (25°C). $V_{IN} = 3.6V$.

Symbol	Description	Conditions	Min	Typ	Max	Units
Power Supply						
V_{IN}	Input operating range		2.7		5.5	V
V_{D_MIN}	Dx pin dropout voltage (90% of nominal current)	All Channels set to 20mA		75	120	mV
I_{SINK}	Output current accuracy	All Channels set to 20mA	-5.0		+5.0	%
		All channels set 0.125mA	-5.0		+5.0	%
I_{SINK}	Output current matching	$ I_D - I_{avg} \text{ max} / I_{avg}$ All Channels set to 20mA	-5.0		5.0	%
I_{IN}	IC supply Current	All 4 Channels set to 20mA		330	650	μA
		All 3 Channels set to 20mA		300		μA
		1 Channel set to 20mA Other channels OFF		260		μA
I_Q	IC quiescent Current	Device on, All LEDs OFF, Reg4 = 0		190		μA
I_{SHDN}	Shutdown current	$V_{IN} = V_{OUT} = 5.5V^5$		0.1	1.0	μA
Control Pin Voltage Specifications (SCL, SDA)						
V_{IL}	Input Logic Low Threshold	SDA, SCL			0.4	V
V_{IH}	Input Logic High Threshold	SDA, SCL	1.2			V
I²C-Compatible Timing Specifications (SCL, SDA), see Figure 1						
t_1	SCL (Clock Period)		2.5			μs
t_2	Data In Setup Time to SCL High		100			ns
t_3	Data Out Stable After SCL Low		0			ns
t_4	SDA Low Setup Time to SCL Low (Start)		100			ns
t_5	Setup time for STOP condition		600			ns
t_{SHDN}	Shutdown Delay			600		μs
Thermal Shutdown						
T_{J_TH}	IC junction thermal shutdown threshold			140		$^{\circ}C$
	IC junction thermal shutdown hysteresis			15		$^{\circ}C$

4. KTD2026/7 are guaranteed to meet performance specifications over the -40°C to +85°C operating temperature range by design, characterization and correlation with statistical process controls.

5. Depending on the Enable Control register Reg0[4-3] and the state of SCL and SDA inputs, the KTD202x enters shutdown mode.

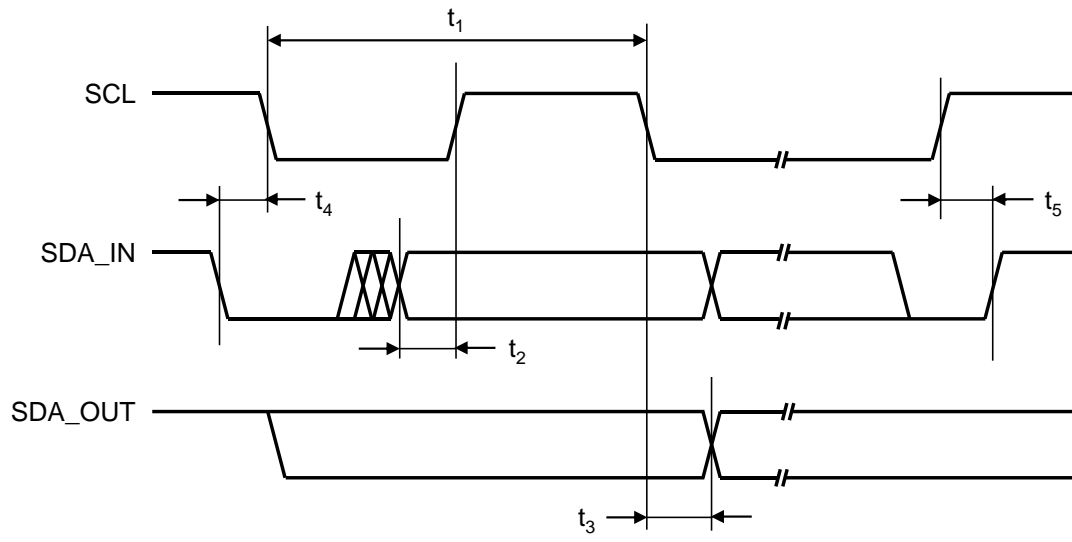
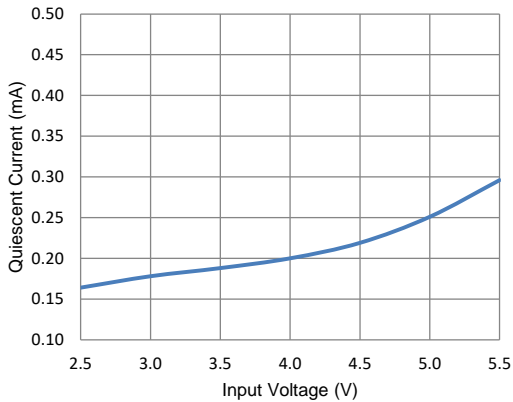

Figure 1. I²C Compatible Interface Timing

Typical Characteristics

$V_{IN} = 3.6V$, $C1 = 1\mu F$, KTD2026, $T_{AMB} = 25^{\circ}C$ unless otherwise specified.

Quiescent Current with LEDs off



Quiescent Current with LEDs on

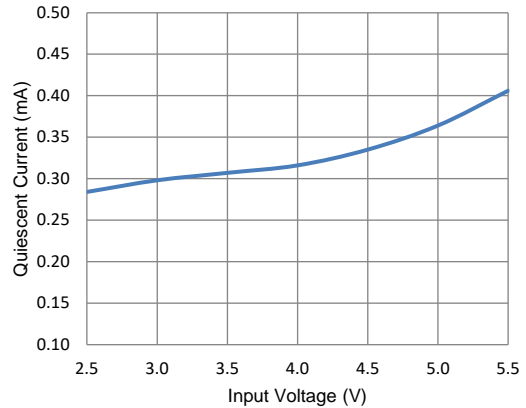

LED Current Regulation (at 20mA)

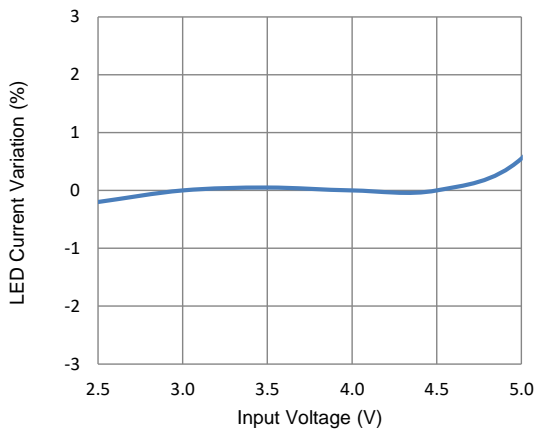

Dropout Voltage

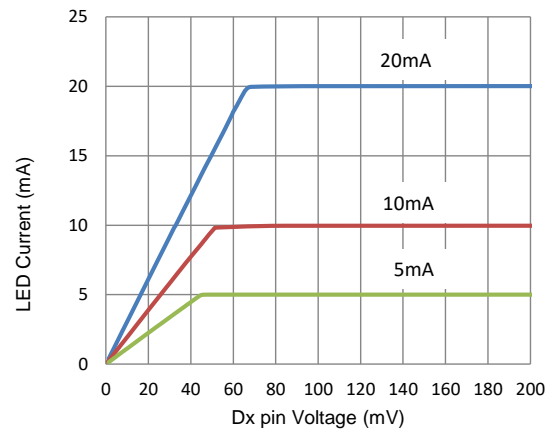

LED Current Matching (2mA per channel)

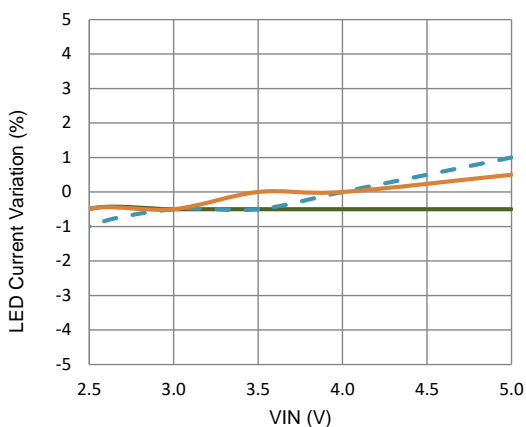

Input Logic Threshold Voltage

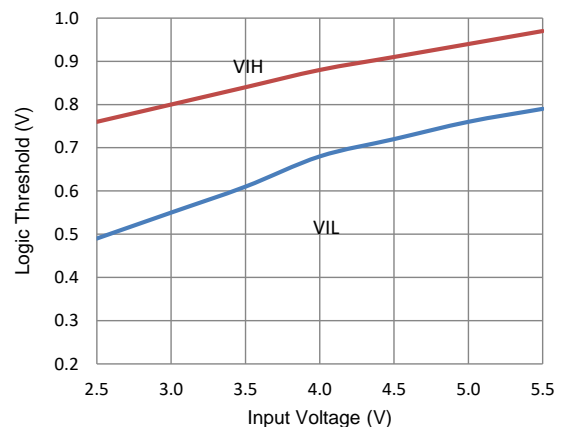

Typical Characteristics

$V_{IN} = 3.6V$, $C1 = 1\mu F$, $T_{AMB} = 25^{\circ}C$ unless otherwise specified.

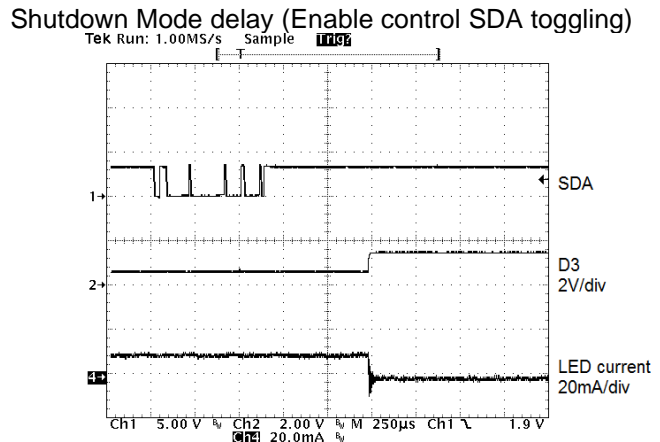
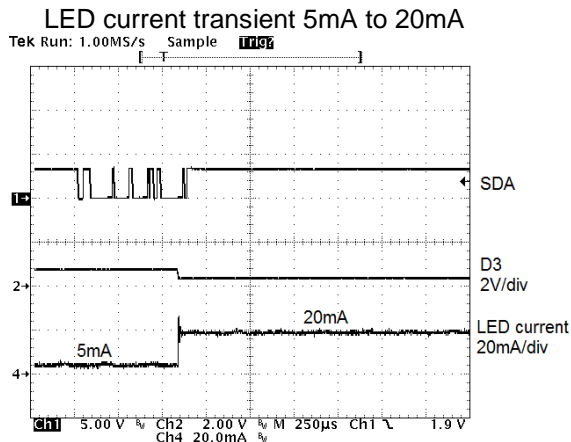
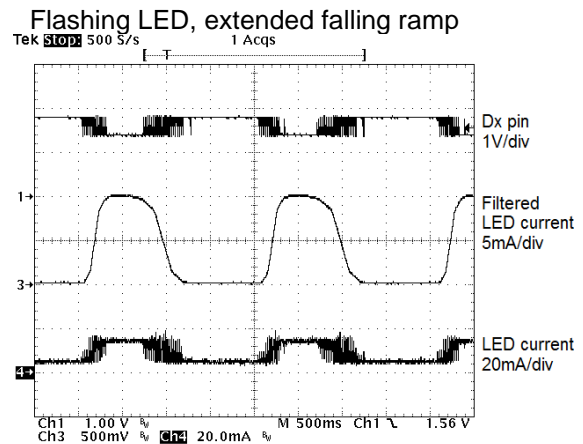
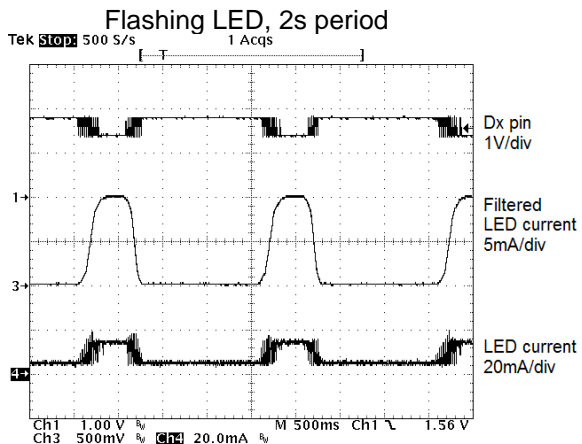
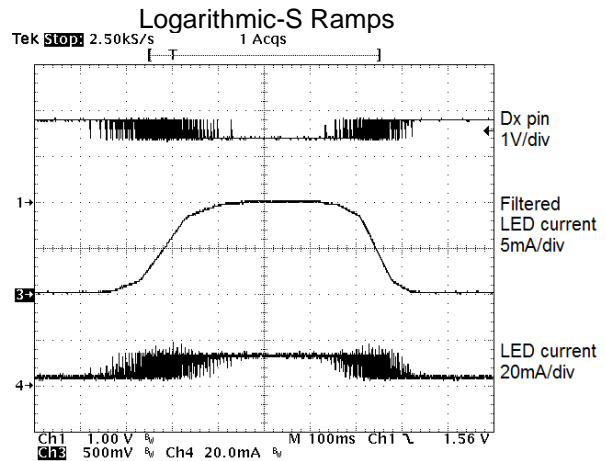
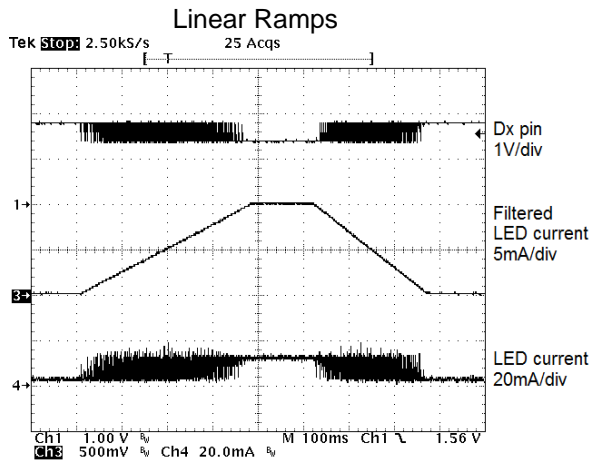

Functional Block Diagram

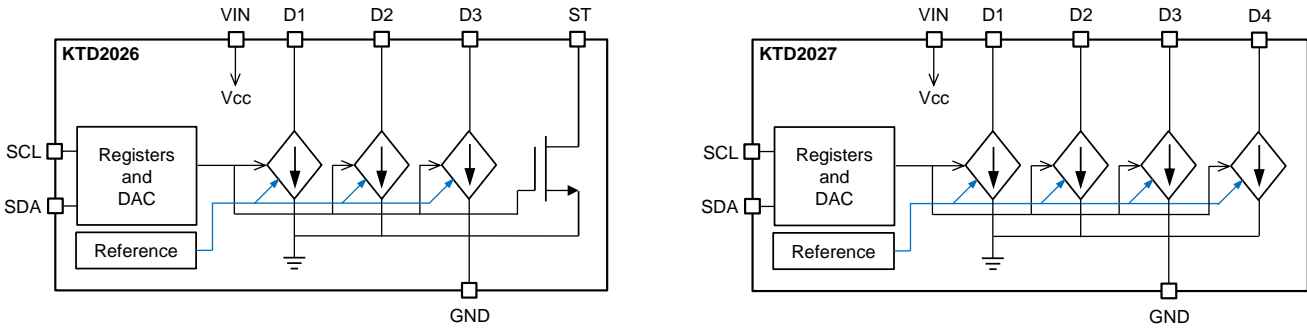

Functional Description

The KTD2026/KTD2027 is a 3- or 4-channel output current sink device, offering constant current regulation with high efficiency and ultralow internal voltage drop. High integration and small size makes it ideal for driving RGB or RGBW LEDs from a one-cell lithium-ion/polymer battery. With a supply voltage range of 2.7V to 5.5V, the KTD2026/KTD2027 is equally suitable for 3- or 4-cell NiCd/NiMH/Alkaline devices or systems with 3.3V or 5V supplies.

The KTD2026/KTD2027 can be programmed using an I2C compatible interface. Each current sink can be configured independently to one of the 192-step current levels or turned off.

LED Current Programming

The individual channel brightness is controlled by the LEDx Iout registers Reg 6 to Reg 9. Each channel has a dedicated 8-bit register for setting the current value. The LED channel current is constant, non-pulsing, except when it is being ramped-up and down.

The ramp up and down are automatically generated using a PWM scheme where the duty cycle is continuously changing (either increasing or decreasing) to provide a smooth LED current transition between the ON and OFF states. The ramp times, for rise and fall, are separately programmable through an internal Ramp register Reg 5 with 4 bits for rise and 4 bits for fall. The ramping can be configured to linear or quasi-logarithmic/s-curve by setting register Reg 1 bit 7 to 1 or 0 respectively.

Flashing LEDs can be performed by programming the time period (Tflash) between two consecutive flashes in the Flash Period register Reg 1. Two Flash On Timer 1/2 registers, Reg 2 and Reg 3, allow to set the LED on time as a percentage of the Flash period. The on time (Ton), shown in Figure 2, includes the ramp-up Trise and the full on time. Two timer registers are available to support two or more LEDs to flash independently. Each channel can be configured to timer1 or timer2 with the Channel Control register Reg 4.

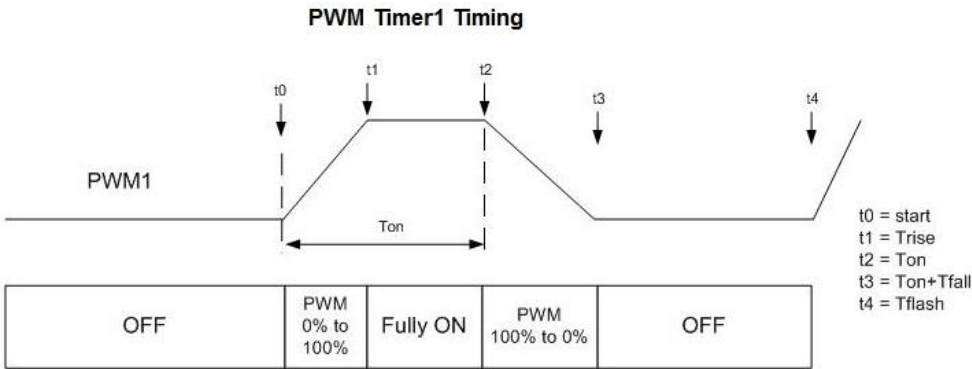

Figure 2. Channel Timing Diagram

Timer Slot Control

The timing diagrams for the four time slots are illustrated below.

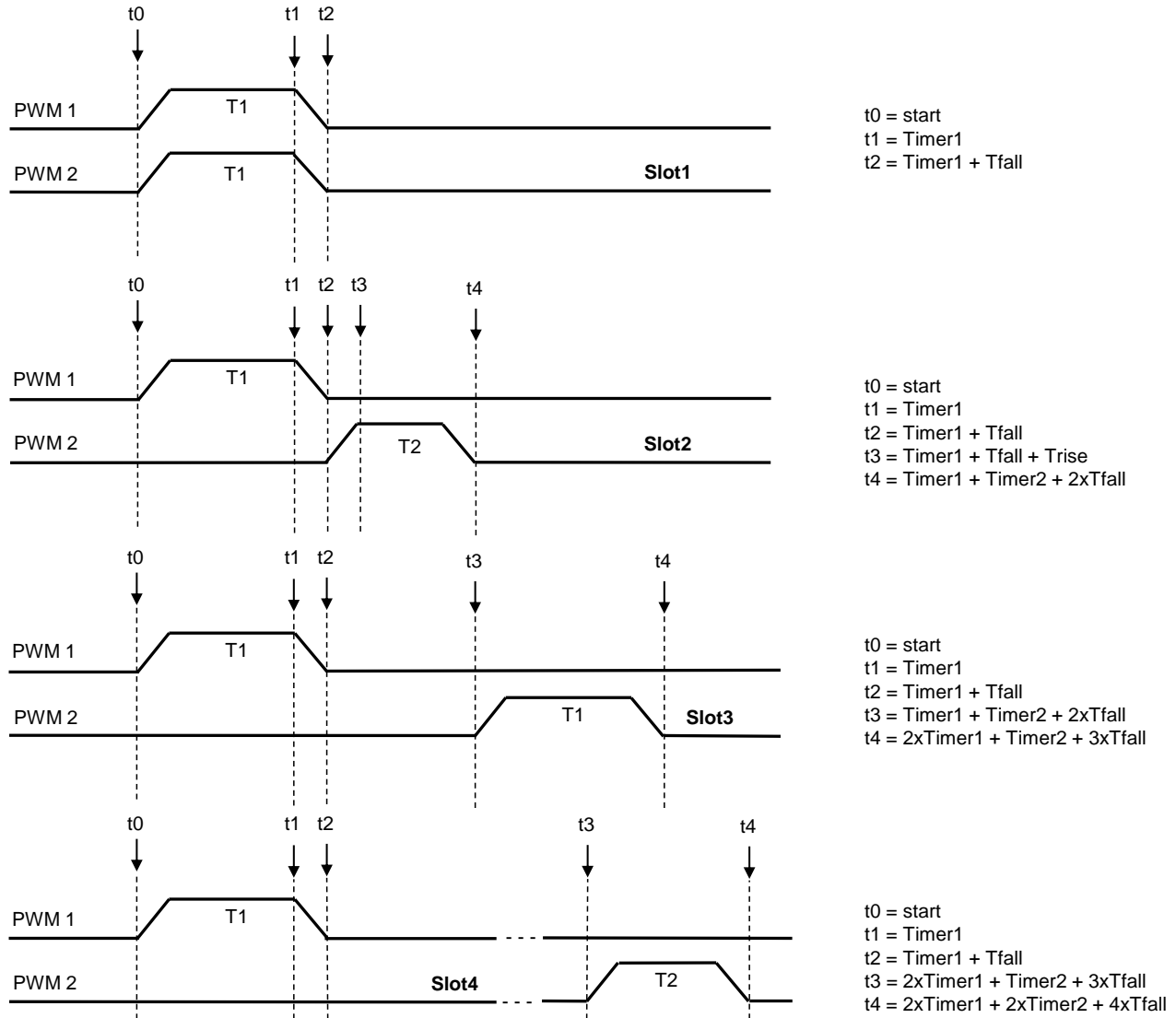
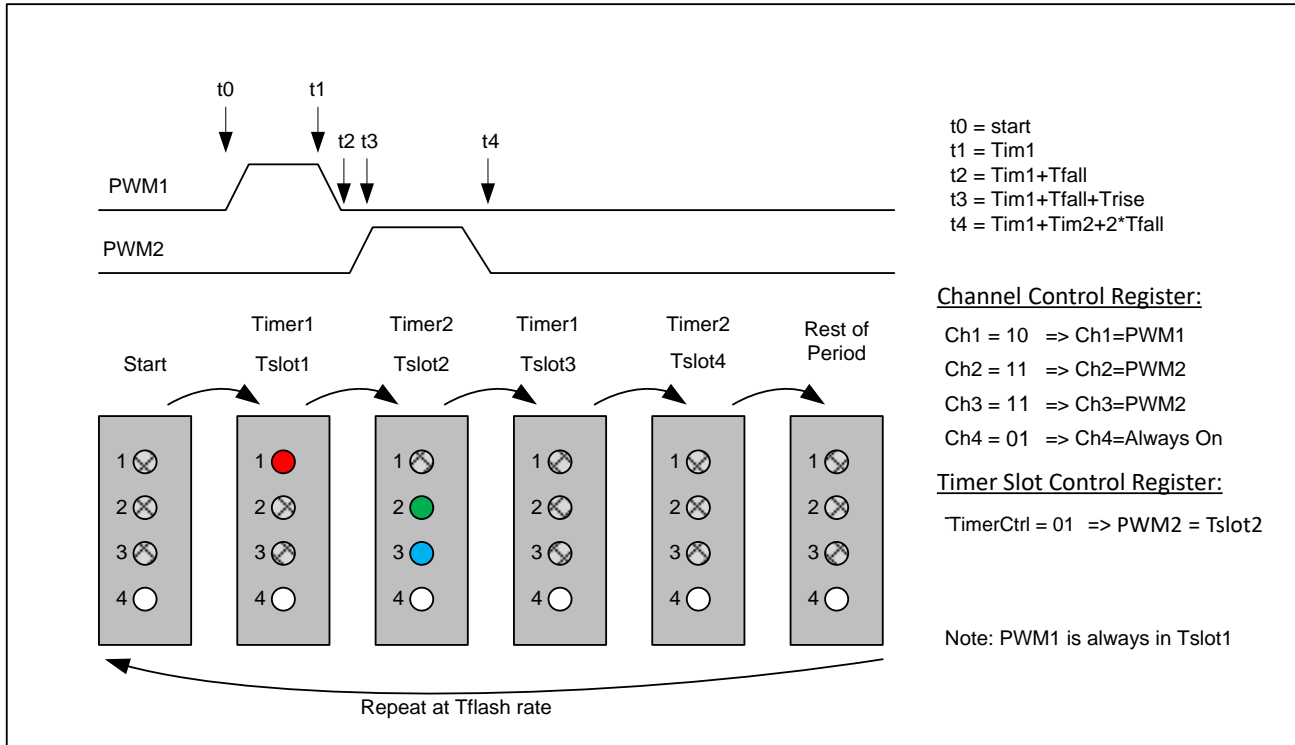
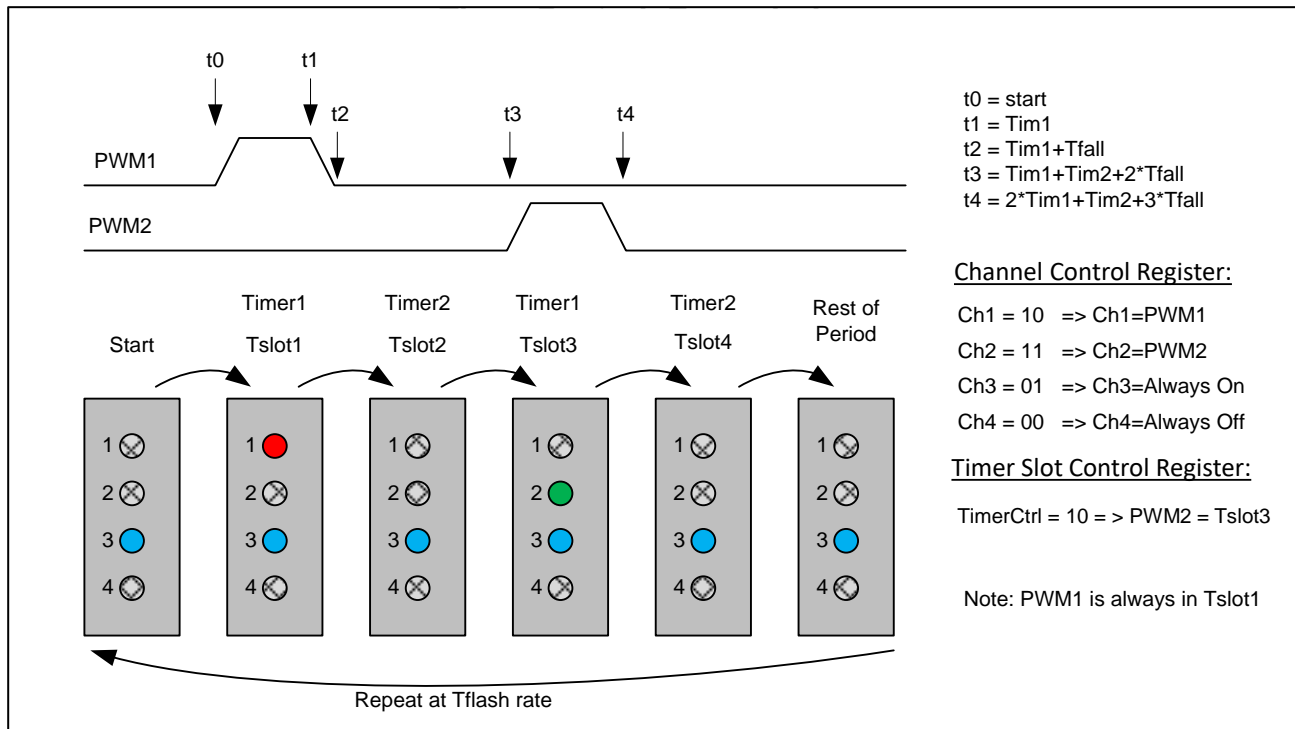

Figure 3. Timer Slot Timing Diagram

Timer Slot2 Example*



Timer Slot3 Example*



*Programming these patterns requires to write to several registers and therefore involves multiple I²C commands.

Each channel can be assigned to one of the 2 time slots, or always OFF or always ON. The Timer Slot Control register bits define the timing of the second PWM waveform.

The Duty Cycle of each flash waveform is set by the timer and can be set with 8-bit resolution (256 steps) between 0 and 100%. The period of the flash repetition rate can also be set with a 7-bit resolution up to 8 seconds (256ms steps starting at 64ms). The Flash repetition period is the same for all outputs. If the programmed total time of the Timers exceed the Flash repetition rate then the PWM2 slot will be terminated and the Timers reset to start position. This may cause the PWM2 signal to be instantly reduced to zero.

Rise/Fall Times

The Ramp-Up and Ramp-Down can be linear or S-shaped profile. The S-shape is the default. The ramp-up transitions from 0% to 100% of the Iset value (ON state) and ramp-down to 0% (OFF state).

LED Basic Control

The brightness setting of each channel is internally controlled by 48 current units of 0.5mA. Output current resolution is increased to an effective 0.125mA steps by interpolation based time division multiplexing (similar to PWM) by a digital interpolator and works on the 2 LSB units of the current setting.

The Stay-Alive/Control Enable Bits are used to permit the Flash pattern to continue or be a one-shot.

Table 1. Register Map

Register Bank											
9	8	7	6	5	4	3	2	1	0		
Iout				General						EN	
LED4 Iout	LED3 Iout	LED2 Iout	LED1 Iout	Trise/fall	Ch Enable	PWM2 Timer	PWM1 Timer	Flash Period	Reset/Control		
x4F	x4F	x4F	x4F	x00	x00	x01	x01	x00	x00	Reset Values	

EN/RST: Reg 0	
0	Timer Slot Control / Reset Control
1	
2	Reset/Offset Cancel
3	En Ctrl
4	
5	Rise/Fall Scaling
6	
7	Test_only

Flash Period: Reg 1	
0	Tflash Period
1	
2	
3	
4	
5	
6	Ramp Linear
7	

Flash On Time 1: Reg 2	
0	PWM1 Timer Percentage of Period
1	
2	
3	
4	
5	
6	
7	

Flash On Time2: Reg 3	
0	PWM2 Timer Percentage of Period
1	
2	
3	
4	
5	
6	
7	

Channel Control: Reg 4	
0	LED1 Enable/Timer1/2
1	
2	LED2 Enable/Timer1/2
3	
4	LED3 Enable/Timer1/2
5	
6	LED4 Enable/Timer1/2
7	

Ramp Rate: Reg 5	
0	Trise
1	
2	
3	Tfall
4	
5	
6	
7	

LED1 Iout: Reg 6	
0	Iout 0.125mA to 24mA in 0.125mA steps
1	
2	
3	
4	
5	
6	
7	

LED2 Iout: Reg 7	
0	Iout 0.125mA to 24mA in 0.125mA steps
1	
2	
3	
4	
5	
6	
7	

LED3 Iout: Reg 8	
0	Iout 0.125mA to 24mA in 0.125mA steps
1	
2	
3	
4	
5	
6	
7	

LED4 Iout: Reg 9	
0	Iout 0.125mA to 24mA in 0.125mA steps
1	
2	
3	
4	
5	
6	
7	

Register Description

Reg0 EN/RST

Reg0 [2:0] Timer Slot Control / Reset Control

TCtrl / Reset Modes			
Reg0[2:0]			Function
D2	D1	D0	
0	0	0	TCtrl: Tslot1
0	0	1	TCtrl: Tslot2
0	1	0	TCtrl: Tslot3
0	1	1	TCtrl: Tslot4
1	0	0	Do Nothing (bit cleared)
1	0	1	Reset Registers only
1	1	0	Reset Main Digital only
1	1	1	Reset Complete Chip

After power-up or VIN dropping below 2.7V, the device should be reset by writing Reg0 = 111 binary. All registers are then restored to their default reset values. After sending the command for complete chip reset Reg0[2:0]=111, a 200µs delay is recommended before the next command to allow the device to execute the complete reset.

Reg0 [4:3] Enable Control

The device enable condition is defined by the two bits Reg0[4:3]. Four different conditions can trigger the device to turn ON depending on the two inputs SCL and SDA.

Enable Control				
Reg0[4:3]		Device ON Condition		Device Enters Shutdown Mode Condition
D1	D0	SCL	SDA	
0	0	High	High	Either SCL or SDA goes low
0	1	High	SDA toggling	Either SCL goes low or SDA stops toggling
1	0	High	Don't care	SCL goes low
1	1	Always ON		Device always ON

Reg0 [6:5] Rise/Fall Time Scaling

These two bits allow to scale the rise and fall times defined in Reg5 ramp rate register.

For example, Reg0[6,5] = 01 (2x slower scaling) and Reg5 = 1, then the rise time = 96ms x 2 = 192ms.

Rise/Fall Time Scaling		
Reg0[6:5]		
D1	D0	
0	0	1x Normal
0	1	2x Slower
1	0	4x Slower
1	1	8x Faster

Bit Reg0[7] must be kept to 0 and is not used in normal operation (reserved for factory test).

Reg1 Flash Period and Reg2/Reg3 ON Timer 1/2

The three registers Reg1, Reg2 and Reg3 allow configuration of the blinking time for the two timers 1/2, associated with PWM1 and PWM2. Reg2 and Reg3 define the LED ON time as a percentage of the period defined in Reg1. The ON time (Ton) includes the ramp rise time as shown in Figure 2.

For example, for Reg1 = 4 and Reg2 = 5, ON timer 1 is equal to 2% of 0.64s = 12.8ms

Reg1[6-0] Flash Period			Reg2/Reg3 Flash ON Timer 1/2		
Dec	Binary	Period[s]	Dec	Binary	Percentage of Period[%]
0	0000000	0.128	0	00000000	0.0%
1	0000001	0.384	1	00000001	0.4%
2	0000010	0.512	2	00000010	0.8%
3	0000011	0.640	3	00000011	1.2%
4	0000100	0.768	4	00000100	1.6%
5	0000101	0.896	5	00000101	2.0%
6	0000110	1.024	6	00000110	2.3%
7	0000111	1.152	7	00000111	2.7%
8	0001000	1.28	8	00001000	3.1%
9	0001001	1.408	9	00001001	3.5%
10	0001010	1.536	10	00001010	3.9%
11	0001011	1.664	11	00001011	4.3%
12	0001100	1.792	12	00001100	4.7%
13	0001101	1.92	13	00001101	5.1%
111	1101111	14.46	239	11101111	93.4%
112	1110000	14.59	240	11110000	93.8%
113	1110001	14.72	241	11110001	94.1%
114	1110010	14.85	242	11110010	94.5%
115	1110011	14.98	243	11110011	94.9%
116	1110100	15.10	244	11110100	95.3%
117	1110101	15.23	245	11110101	95.7%
118	1110110	15.36	246	11110110	96.1%
119	1110111	15.49	247	11110111	96.5%
120	1111000	15.62	248	11111000	96.9%
121	1111001	15.74	249	11111001	97.3%
122	1111010	15.87	250	11111010	97.7%
123	1111011	16.0	251	11111011	98.0%
124	1111100	16.13	252	11111100	98.4%
125	1111101	16.26	253	11111101	98.8%
126	1111110	16.38	254	11111110	99.2%
127	1111111	One Shot	255	11111111	99.6%

Reg1[7] Ramp Linear

The default setting, bit Reg1[7] = 0, provides with a logarithmic-like S ramp up and down curve. By setting this bit to 1, the ramp becomes a simple linear up and down waveform.

Reg4 LED Enable Control

Register Reg4 sets the mode of each LED channel to either always ON/OFF or PWM1/PWM2.

For example Reg4 = 00000001(binary), sets LED1 ON and other channels OFF.

LED Enable (1/2/3/4)		
Dec	Binary	Function
0	00	Always OFF
1	01	Always ON
2	10	PWM1
3	11	PWM2

Reg5 Ramp Times

The register Reg5 sets the rise and fall time durations for the LED current ramp transitioning between 0mA and the nominal current. The rise and fall ramp times are defined by 4 bits Reg5[3-0] and Reg5[7-4] respectively.

For example, Reg5 = 4 and Reg0[6,5] = 0 (1x ramp scaling), then the rise time is equal to 512ms.

Trise Reg5[3-0] Tfall Reg5[7-4]		Ramp Time [ms]			
		Ramp Scaling ⁶			
Dec	Binary	00 1x	01 2x slower	10 4x slower	11 8x faster
0	0000 (Default)	2	2	2	2
1	0001	128	256	512	16
2	0010	256	512	1024	32
3	0011	384	768	1536	48
4	0100	512	1024	2048	64
5	0101	640	1280	2560	80
6	0110	768	1536	3072	96
7	0111	896	1792	3584	112
8	1000	1024	2048	4096	128
9	1001	1152	2304	4608	144
10	1010	1280	2560	5120	160
11	1011	1408	2816	5632	176
12	1100	1536	3072	6144	192
13	1101	1664	3328	6656	208
14	1110	1792	3584	7168	224
15	1111	1920	3840	7680	240

6. There is only one Ramp Scaling register for both the rise and fall times.

Reg6, Reg7, Reg8, Reg9 LED Current Setting

Registers Reg6 to Reg9 define the LED current setting for the channels D1 to D4 respectively. The LED current can be programmed to 192 levels between 0.125mA minimum and 24mA maximum with 0.125mA step.

For example, 24mA is set by the code BF hexadecimal (191 decimal, 1011 1111 binary) or any higher code value. 10mA current is set by the code 4F hexadecimal (79 decimal, 0100 1111 binary)

Iout (mA)	Data Dec	Data Hexa	Bit 7	Bit 6	Bit 5	Bit 4	Bit 3	Bit 2	Bit 1 ⁷	Bit 0 ⁷
0.125	0 (default)	00h (default)	0	0	0	0	0	0	0	0
0.25	1	01h	0	0	0	0	0	0	0	1
0.38	2	02h	0	0	0	0	0	0	1	0
0.50	3	03h	0	0	0	0	0	0	1	1
10.00	79	4Fh	0	1	0	0	1	1	1	1
10.13	80	50h	0	1	0	1	0	0	0	0
20.00	159	9Fh	1	0	0	1	1	1	1	1
20.13	160	A0h	1	0	1	0	0	0	0	0
23.88	190	BEh	1	0	1	1	1	1	1	0
24.00	191	BFh	1	0	1	1	1	1	1	1
24.00	192	C0h	1	1	0	0	0	0	0	0
24.00	254	FEh	1	1	1	1	1	1	1	0
24.00	255	FFh	1	1	1	1	1	1	1	1

7. The 2 LSB's are timed division multiplexed (similar to PWM) by a digital interpolator. Minimum Iout unit is 0.5mA.

Application Information

I²C Interface Protocol

On the KTD2026/KTD2027, the ten internal registers Reg0 to Reg9 can be accessed via the I²C interface. The I²C device address of KTD2026/KTD2027 is 0x30 hexadecimal or 110000 binary, KTD2026B device address is 0x31 hexadecimal or 110001 binary and KTD2026C device address is 0x32 hexadecimal or 110010 binary. The read and write commands allow to modify the content of each register. For further details on the I²C protocol, please refer to the I²C-Bus Specification, document number 9398 393 40011, from Philips Semiconductors.

The protocol for Write and Read is the following.

Write:

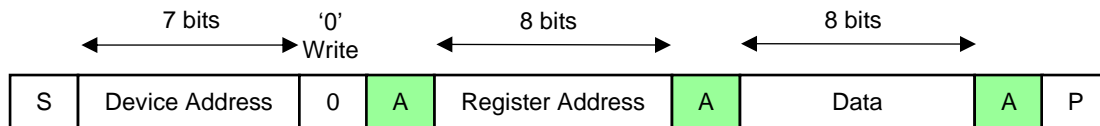

where

S = START condition

P = STOP condition

Device Address = 0110000 (7 bits, MSB first) [KTD2026B=0110001, KTD2026C=0110010]

Register Address = Reg0 - Reg9 address (8 bits)

Data = data to read or write (8 bits)

1 = Read command bit

0 = Write command bit

A = acknowledge (SDA low)

A* = not acknowledge (SDA high)



From master to slave (KTD2026/7)



From slave (KTD2026/7) to master

For example, the command to write KTD2026/KTD2027 register Reg4 (address 4) = 0, LEDs always OFF:

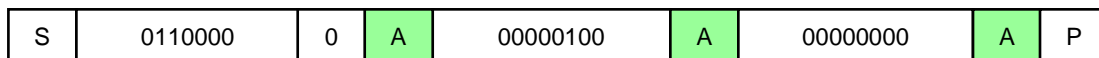

Note: For the I²C Reset commands (“Reset Register only” and “Reset Complete Chip”), the last byte is followed by a “not acknowledge” (SDA high). For these two commands, the lack of acknowledge at the end of the command is to be ignored.

Read:

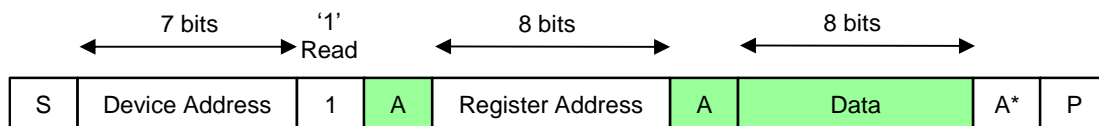

The KTD2026/KTD2027 can wake-up from shutdown mode by toggling the SDA input.

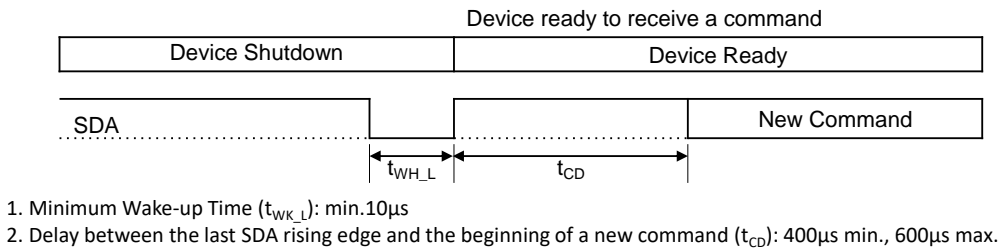

Figure 4. Wake-up from Shutdown Mode

Power Saving, Sleep mode

When the KTD2026/KTD2027 is not driving LEDs, for example when all LEDs are off, the driver current consumption can be set to “zero current” by putting the device into shutdown or sleep mode.

The register content is preserved while the KTD2026/KTD2027 goes into shutdown/sleep mode. To restart with LEDs off, LEDs should be turned off by writing zero into the LED Enable Control register Reg4 before entering the sleep mode.

For the KTD2026/KTD2027, it is possible to force the device in sleep mode as long as there is no activity on the SDA line by writing the Enable Control mode register Reg0[4:3] = 01 to select the “SCL=High & SDA Toggling” mode.

The following sequence shows an example where LED3 is flashing initially, then the device is set to sleep mode, then the part is restarted.

LED3 (blue) is flashing. KTD2026 VIN pin current (I_{IN}) = 260 μ A typical.

To enter sleep mode: Write Enable Control mode register Reg0[4:3] = 01, for mode “SCL=High & SDA Toggling”. LEDs are now off. I_{IN} = “zero” when there is no activity on the SDA line.

To restart the driver: Write Enable Control mode register Reg0[4:3] = 00, for mode “SCL & SDA High”. LED3 (blue) is flashing. I_{IN} = 260 μ A.

Voltage Headroom

The lowest headroom voltage is critical for systems with supply voltages nearing 3V, such as battery operated or regulated 3.3V systems. The advancement of LED technologies has made possible lower LED current and lower forward voltage drop (VF). For example, the majority of vendors’ Blue LED’s VF at 5mA is 3.15V or below. With the cut-off voltage for most 1-cell Li+ powered systems set between 3.3V and 3.5V, it is possible to drive RGB LEDs without voltage step-up as long as the internal voltage drop for the driver circuit is specially designed for the lowest voltage possible.

Each current sink of the KTD2026/KTD2027 is designed to allow the lowest operating input voltage without voltage step-up while maintaining current regulation, thus extending the battery run time. When input voltage is low, the internal low impedance current sink adds merely 75mV (typical) headroom on top of the LED forward voltage at 24mA per channel.

The formula is: $V_{IN(MIN)} = V_{F(MAX)} + V_{SINK(MIN)}$,

where V_{IN} is the driving voltage applied to the anode of each LED, V_F is the forward voltage drop of the LED, and V_{SINK} is the voltage at each Dx. When V_{IN} is high (fully charged battery), V_{SINK} is internally regulated to take the voltage difference between V_{IN} and V_F . For instance, if V_{IN} is 4V and V_F for LED1 is 3.1V, then V_{SINK} at D1 pin is 0.9V.

When V_{IN} decreases (as the battery discharges), $V_{IN(MIN)}$ governs the lowest supply voltage for the LEDs without losing regulation. The design rule of thumb is to make sure the cut-off voltage is higher than $V_{IN(MIN)}$ for all conditions. It is important to emphasize the definition of “losing regulation”; in this datasheet it is defined as when the LED current drops to 90% of the nominal programmed current level.

At 24mA, the typical VSINK can be as low as 75mV for each Dx pin. Since every LED has a slightly different VF at a given current, the minimum VIN is determined by the highest VF plus 75mV typical. For the case of 24mA programmed current and highest VF of 3.2V, VIN in can go as low as 3.275V without losing LED current regulation. When VIN drops further while the VSINK(MIN) remains constant, VF will be forced lower. As a result, the LED current will reduce according to each LED's V-I curve.

Recommended PCB Layout

The input capacitor C1 should be mounted between the VIN pin and the ground plane close to the UTDFN package. The GND pin should be connected to the GND plane and to the center pad underneath the package. The package exposed pad should be soldered to the ground plane to improve the thermal dissipation.

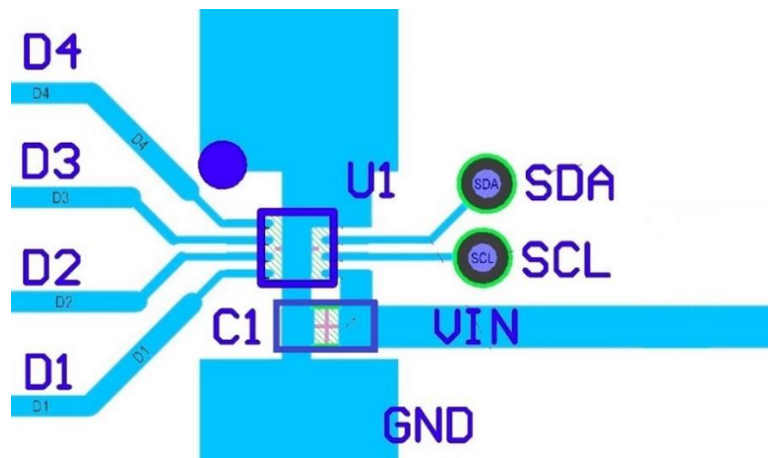

Packaging Information

UTDFN 1.5x1.5 – 8 pin

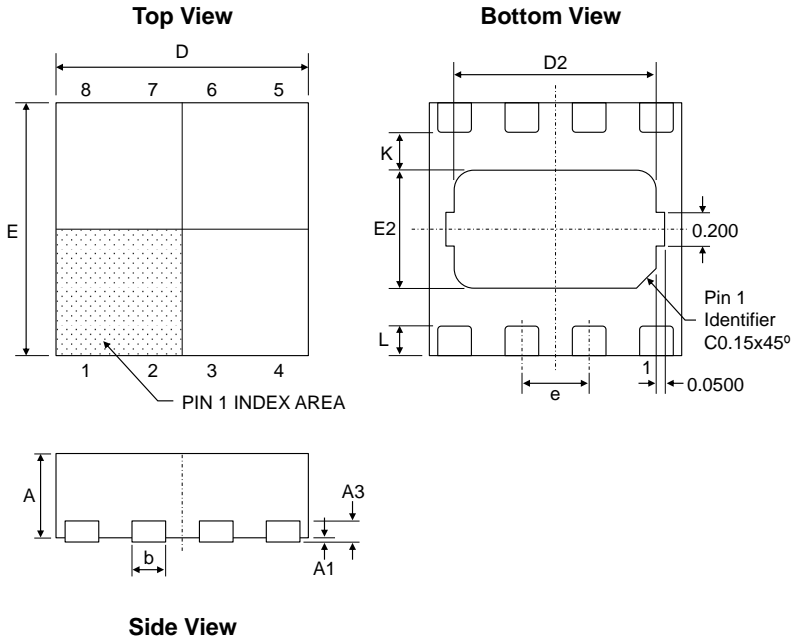

Dimension	mm		
	Min.	Typ.	Max.
A	0.45	0.50	0.55
A3	0.127 REF.		
A1	0.00	0.02	0.05
b	0.15	0.20	0.25
D	1.45	1.50	1.55
D2	1.15	1.20	1.25
E	1.45	1.50	1.55
E2	0.65	0.70	0.75
e	0.40 BSC		
L	0.125	0.175	0.225
K	0.200	-	-

Recommended Footprint

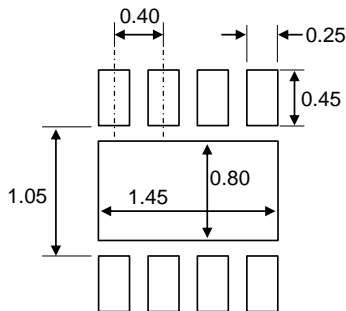

* Dimensions are in millimeters.

Tape and Reel Specifications

Reel Dimensions

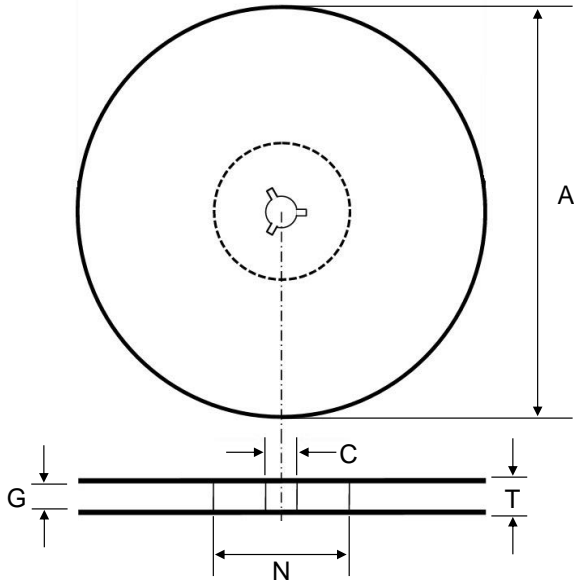

Dimension	mm		
	Min.	Typ.	Max.
A	176	178	180
C	12.8	13.0	13.5
G	7.9	—	10.9
N	50	55	60
T	—	—	14.4

Tape Dimensions

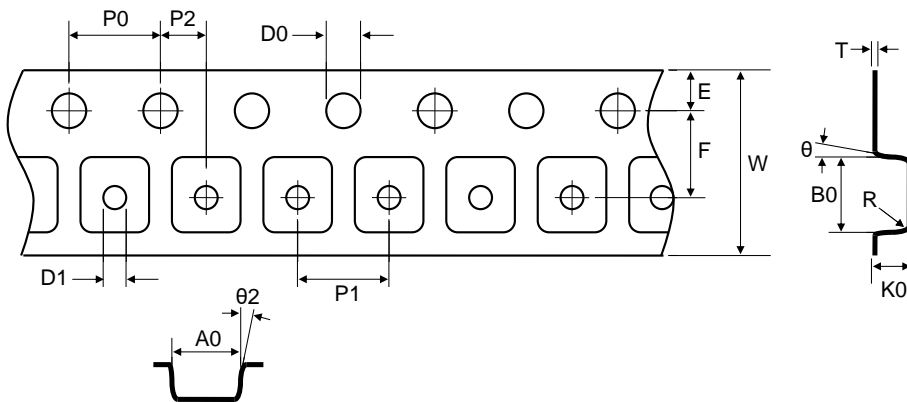

Dimension	mm		
	Min.	Typ.	Max.
A0	1.65	1.70	1.75
B0	1.65	1.70	1.75
K0	0.65	0.70	0.75
P0	3.9	4.0	4.1
P1	3.9	4.0	4.1
P2	1.95	2.00	2.05
D0	1.5	1.55	1.6
D1	1.00	—	—
E	1.65	1.75	1.85
F	3.45	3.50	3.55
10P0	39.8	40.0	40.2
W	7.9	8.0	8.3
T	0.18	0.20	0.22
θ	0°	—	5°
$\theta 2$	0°	—	5°

Kinetic Technologies cannot assume responsibility for use of any circuitry other than circuitry entirely embodied in a Kinetic Technologies product. No intellectual property or circuit patent licenses are implied. Kinetic Technologies reserves the right to change the circuitry and specifications without notice at any time.

Looking for pricing, stock, or lifecycle information?

Click below to explore more details on WIN SOURCE:

 [View KTD2027EWE-TR on WIN SOURCE](#)

 [Kinetic Information](#)

Optimize Your Supply Chain with WIN SOURCE Solutions

-  Global Sourcing Solution
-  Obsolete Management
-  Cost Control Management
-  Shortage Management
-  Alternative Solution
-  Excess Inventory Management