



## OVERVOLTAGE AND OVERCURRENT PROTECTION IC AND Li+ CHARGER FRONT-END PROTECTION IC

### FEATURES

- Provides Protection for Three Variables:
  - Input Overvoltage, with Rapid Response in  $< 1 \mu\text{s}$
  - User-Programmable Overcurrent with Current Limiting
  - Battery Overvoltage
- 30V Maximum Input Voltage
- Supports up to 1.5A Input Current
- Robust Against False Triggering Due to Current Transients
- Thermal Shutdown
- Enable Input
- Status Indication – Fault Condition

- 5.5V LDO Mode Voltage Regulation
- Available in Space-Saving Small 8 Lead 2mm x2mm SON

### APPLICATIONS

- Mobile Phones and Smart Phones
- PDAs
- MP3 Players
- Low-Power Handheld Devices
- Bluetooth™ Headsets

### DESCRIPTION

The bq24313 and bq24315 are highly integrated circuits designed to provide protection to Li-ion batteries from failures of the charging circuit. The IC continuously monitors the input voltage, the input current, and the battery voltage. The output acts as a linear regulator. The output is regulated to  $V_{O(REG)}$  for inputs between  $V_{O(REG)}$  and the overvoltage threshold. If an input overvoltage condition occurs, the IC immediately removes power from the charging circuit by turning off an internal switch. In the case of an overcurrent condition, it limits the system current at the threshold value, and if the overcurrent persists, switches the pass element OFF after a blanking period. Additionally, the IC also monitors its own die temperature and switches off if it exceeds  $140^{\circ}\text{C}$ . The input overcurrent threshold is user-programmable.

The IC can be controlled by a processor and also provides status information about fault conditions to the host.

### APPLICATION SCHEMATIC

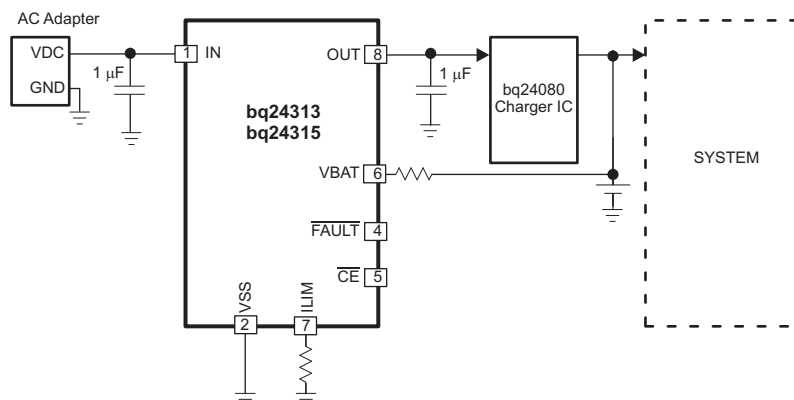

Please be aware that an important notice concerning availability, standard warranty, and use in critical applications of Texas Instruments semiconductor products and disclaimers thereto appears at the end of this data sheet.

PowerPAD is a trademark of Texas Instruments.

Bluetooth is a trademark of Bluetooth SIG, Inc.



These devices have limited built-in ESD protection. The leads should be shorted together or the device placed in conductive foam during storage or handling to prevent electrostatic damage to the MOS gates.

### ORDERING INFORMATION<sup>(1)</sup>

DEVICE <sup>(2)</sup>	OVP THRESHOLD	PACKAGE	MARKING
bq24313DSG	10.5V	2mm x 2mm SON	NXQ
bq24315DSG	5.85 V	2mm x 2mm SON	CGM

- (1) For the most current package and ordering information, see the Package Option Addendum at the end of this document, or see the TI website at [www.ti.com](http://www.ti.com).  
 (2) To order a 3000 piece reel add R to the part number, or to order a 250 piece reel add T to the part number.

### PACKAGE DISSIPATION RATINGS

DESIGNATOR	PACKAGE	R <sub>θJC</sub>	R <sub>θJA</sub>
DSG	2x2 SON	5°C/W	75°C/W

### ABSOLUTE MAXIMUM RATINGS<sup>(1)</sup>

over operating free-air temperature range (unless otherwise noted)

	PARAMETER	PIN	VALUE	UNIT
V <sub>I</sub>	Input voltage	IN (with respect to VSS)	−0.3 to 30	V
		OUT (with respect to VSS)	−0.3 to 12	
		ILIM, FAULT, CE, VBAT (with respect to VSS)	−0.3 to 7	
I <sub>I</sub>	Input current	IN	2	A
I <sub>O</sub>	Output current	OUT	2	A
	Output sink current	FAULT	15	mA
ESD	Withstand Voltage	All (Human Body Model per JESD22-A114-E)	2000	V
		All (Machine Model per JESD22-A115-E)	200	V
		All (Charge Device Model per JESD22-C101-C)	500	V
		IN(IEC 61000-4-2) (with IN bypassed to the VSS with a 1-μF low-ESR ceramic capacitor)	15 (Air Discharge) 8 (Contact)	kV
T <sub>J</sub>	Junction temperature		−40 to 150	°C
T <sub>stg</sub>	Storage temperature		−65 to 150	°C

- (1) Stresses beyond those listed under absolute maximum ratings may cause permanent damage to the device. These are stress ratings only, and functional operation of the device at these or any other conditions beyond those indicated under recommended operating conditions is not implied. Exposure to absolute-maximum-rated conditions for extended periods may affect device reliability. All voltage values are with respect to the network ground terminal unless otherwise noted.

### RECOMMENDED OPERATING CONDITIONS

over operating free-air temperature range (unless otherwise noted)

		MIN	MAX	UNIT
V <sub>IN</sub>	Input voltage range	3.3	30	V
I <sub>IN</sub>	Input current, IN pin		1.5	A
I <sub>OUT</sub>	Output current, OUT pin		1.5	A
R <sub>(ILIM)</sub>	OCP Programming resistor	15	90	kΩ
T <sub>J</sub>	Junction temperature	−40	125	°C

## ELECTRICAL CHARACTERISTICS

 over junction temperature range  $-40^{\circ}\text{C}$  to  $125^{\circ}\text{C}$  and recommended supply voltage (unless otherwise noted)

PARAMETER		TEST CONDITIONS	MIN	TYP	MAX	UNIT	
<b>IN</b>							
UVLO	Undervoltage lock-out, input power detected threshold	$\overline{\text{CE}} = \text{Low}$ , $V_{\text{IN}}$ increasing from 0V to 3V	2.6	2.7	2.8	V	
$V_{\text{hys}}(\text{UVLO})$	Hysteresis on UVLO	$\overline{\text{CE}} = \text{Low}$ , $V_{\text{IN}}$ decreasing from 3V to 0V	200	260	300	mV	
$t_{\text{DGL}}(\text{PGOOD})$	Deglintch time, input power detected status	$\overline{\text{CE}} = \text{Low}$ . Time measured from $V_{\text{IN}}$ 0V $\rightarrow$ 5V 1 $\mu\text{s}$ rise-time, to output turning ON		8		ms	
$I_{\text{DD}}$	Operating current	$\overline{\text{CE}} = \text{Low}$ , No load on OUT pin, $V_{\text{IN}} = 5\text{V}$ , $R_{(\text{ILIM})} = 25\text{k}\Omega$		400	600	$\mu\text{A}$	
$I_{\text{STDBY}}$	Standby current	$\overline{\text{CE}} = \text{High}$ , $V_{\text{IN}} = 5\text{V}$		65	95	$\mu\text{A}$	
<b>INPUT TO OUTPUT CHARACTERISTICS</b>							
$V_{\text{DO}}$	Drop-out voltage IN to OUT	$\overline{\text{CE}} = \text{Low}$ , $V_{\text{IN}} = 5\text{V}$ , $I_{\text{OUT}} = 1\text{A}$		170	280	mV	
<b>OUTPUT VOLTAGE REGULATION</b>							
$V_{\text{O(REG)}}$	Output voltage	$\overline{\text{CE}} = \text{Low}$ , $V_{\text{IN}} = 6.5\text{V}$ , $I_{\text{OUT}} = 1\text{A}$	bq24313	5.67	5.85	6.03	V
		$\overline{\text{CE}} = \text{Low}$ , $V_{\text{IN}} = 5.7\text{V}$ , $I_{\text{OUT}} = 1\text{A}$	bq24315	5.3	5.5	5.7	
<b>INPUT OVERVOLTAGE PROTECTION</b>							
$V_{\text{OVP}}$	Input overvoltage protection threshold	$\overline{\text{CE}} = \text{Low}$ , $V_{\text{IN}}$ increasing from 5V to 11V	bq24313	10.2	10.5	10.8	V
			bq24315	5.71	5.85	6.00	
$t_{\text{PD}}(\text{OVP})$	Input OV propagation delay <sup>(1)</sup>	$\overline{\text{CE}} = \text{Low}$		200		ns	
$V_{\text{hys}}(\text{OVP})$	Hysteresis on OVP	$\overline{\text{CE}} = \text{Low}$ , $V_{\text{IN}}$ decreasing from 11V to 5V	bq24313	60	120	180	mV
			bq24315	20	60	110	
$t_{\text{ON}}(\text{OVP})$	Recovery time from input overvoltage condition	$\overline{\text{CE}} = \text{Low}$ , Time measured from $V_{\text{IN}}$ 7.5V $\rightarrow$ 5V, 1 $\mu\text{s}$ fall-time		8		ms	
<b>INPUT OVERCURRENT PROTECTION</b>							
$I_{\text{OCP}}$	Input overcurrent protection threshold range		300		1500	mA	
$I_{\text{OCP}}$	Input overcurrent protection threshold	$\overline{\text{CE}} = \text{Low}$ , $R_{(\text{ILIM})} = 24.9\text{k}\Omega$ , $3\text{V} \leq V_{\text{IN}} < V_{\text{OVP}} - V_{\text{hys}}(\text{OVP})$	900	1000	1100	mA	
$K_{(\text{ILIM})}$	Adjustable current limit factor			25		A = k $\Omega$	
$t_{\text{BLANK}}(\text{OCP})$	Blanking time, input overcurrent detected			176		$\mu\text{s}$	
$t_{\text{REC}}(\text{OCP})$	Recovery time from input overcurrent condition			64		ms	
<b>BATTERY OVERVOLTAGE PROTECTION</b>							
$BV_{\text{OVP}}$	Battery overvoltage protection threshold	$\overline{\text{CE}} = \text{Low}$ , $V_{\text{IN}} > 4.4\text{V}$	4.30	4.35	4.4	V	
$V_{\text{hys}}(\text{BoVp})$	Hysteresis on $BV_{\text{OVP}}$	$\overline{\text{CE}} = \text{Low}$ , $V_{\text{IN}} > 4.4\text{V}$	200	275	320	mV	
$I_{(\text{VBAT})}$	Input bias current on VBAT pin	$V_{(\text{VBAT})} = 4.4\text{V}$ , $T_{\text{J}} = 25^{\circ}\text{C}$			10	nA	
$t_{\text{DGL}}(\text{BoVp})$	Deglintch time, battery overvoltage detected	$\overline{\text{CE}} = \text{Low}$ , $V_{\text{IN}} > 4.4\text{V}$ . Time measured from $V_{(\text{VBAT})}$ rising from 4.1V to 4.4V to FAULT going low.		176		$\mu\text{s}$	
<b>THERMAL PROTECTION</b>							
$T_{\text{J(OFF)}}$	Thermal shutdown temperature			140	150	$^{\circ}\text{C}$	
$T_{\text{J(OFF-HYS)}}$	Thermal shutdown hysteresis			20		$^{\circ}\text{C}$	
<b>LOGIC LEVELS ON <math>\overline{\text{CE}}</math></b>							
$V_{\text{IL}}$	Low-level input voltage		0		0.4	V	
$V_{\text{IH}}$	High-level input voltage		1.4			V	
$I_{\text{IL}}$	Low-level input current	$V_{(\text{CE})} = 0\text{V}$			1	$\mu\text{A}$	

(1) Not tested in production. Specified by design.

**ELECTRICAL CHARACTERISTICS (continued)**over junction temperature range  $-40^{\circ}\text{C}$  to  $125^{\circ}\text{C}$  and recommended supply voltage (unless otherwise noted)

PARAMETER		TEST CONDITIONS	MIN	TYP	MAX	UNIT
$I_{IH}$	High-level input current	$V_{(CE)} = 1.8\text{V}$			15	$\mu\text{A}$
<b>LOGIC LEVELS ON FAULT</b>						
$V_{OL}$	Output low voltage	$I_{SINK} = 5\text{mA}$			0.2	V
$I_{Lkg}$	Leakage current, $\overline{\text{FAULT}}$ pin HI-Z	$V_{(\text{FAULT})} = 5\text{V}$			10	$\mu\text{A}$

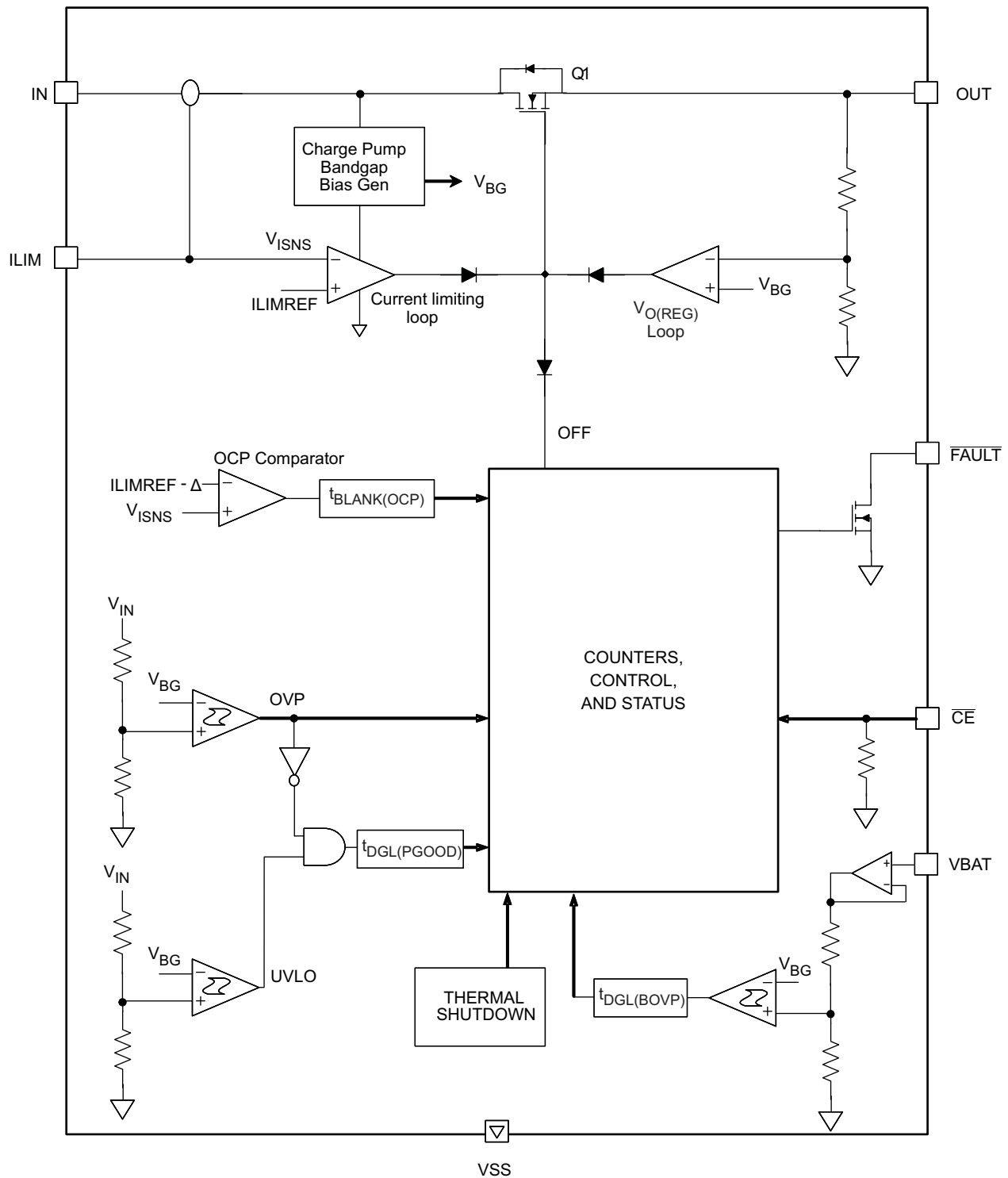
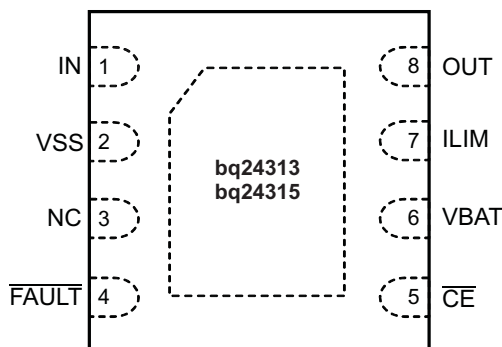

Figure 1. Simplified Block Diagram

**TERMINAL FUNCTIONS**

TERMINAL		I/O	DESCRIPTION
NAME	DSG		
IN	1	I	Input power. Connect IN to the external DC supply. Bypass IN to VSS with a 1µF ceramic capacitor (minimum).
VSS	2	–	Ground terminal
NC	3		This pin may have internal circuits used for test purposes. Do not make any external connection to this pin for normal operation.
$\overline{\text{FAULT}}$	4	O	Open-drain, device status output. $\overline{\text{FAULT}}$ = Low indicates that the input FET Q1 is off due to input overvoltage, input overcurrent, battery overvoltage, or thermal shutdown. $\overline{\text{FAULT}}$ is high impedance during normal operation. Connect a pullup resistor from $\overline{\text{FAULT}}$ to the desired logic level voltage rail.
$\overline{\text{CE}}$	5	I	Chip enable active low input. Connect $\overline{\text{CE}}$ = High to disable the IC and turn the input FET off. Connect $\overline{\text{CE}}$ = low for normal operation. $\overline{\text{CE}}$ is internally pulled down.
VBAT	6	I	Battery voltage sense input. Connect to the battery pack positive terminal through a resistor.
ILIM	7	I/O	Input overcurrent threshold programming. Connect a resistor from ILIM to VSS to set the overcurrent threshold.
OUT	8	O	Output terminal to the charging system. Connect OUT to the external load circuitry. Bypass OUT to VSS with a 1µF ceramic capacitor (minimum).
Thermal PAD		–	There is an internal electrical connection between the exposed thermal pad and the VSS pin of the device. The thermal pad must be connected to the same potential as the VSS pin on the printed circuit board. Do not use the thermal pad as the primary ground input for the device. The VSS pin must be connected to ground at all times.

**DSG Package  
(Top View)**



### TYPICAL OPERATING PERFORMANCE

Test conditions (unless otherwise noted) for typical operating performance:  $V_{IN} = 5\text{ V}$ ,  $C_{IN} = 1\ \mu\text{F}$ ,  $C_{OUT} = 1\ \mu\text{F}$ ,  $R_{(LIM)} = 25\ \text{k}\Omega$ ,  $R_{BAT} = 100\ \text{k}\Omega$ ,  $T_A = 25^\circ\text{C}$ ,  $V_{PU} = 3.3\text{ V}$  (see Figure 22 for the Typical Application Circuit)

**NORMAL POWER-ON SHOWING SOFT-START**

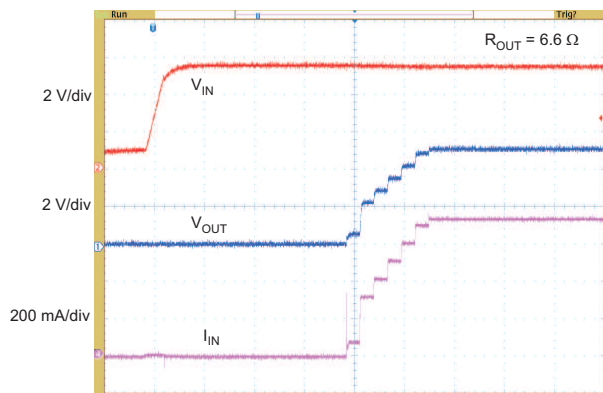

t - Time - 2 ms/div

Figure 2.

**OVP AT POWER-ON**

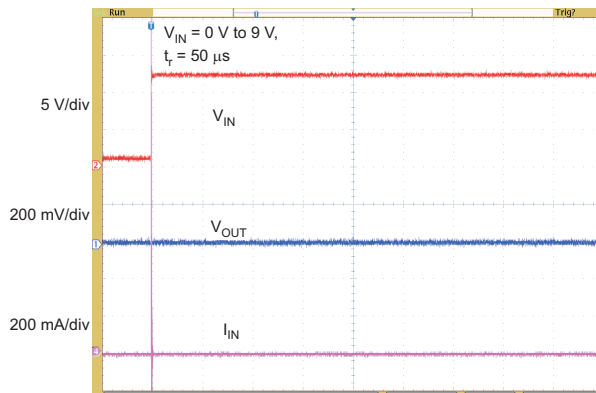

t - Time - 2 ms/div

Figure 3.

**OVP RESPONSE FOR INPUT STEP**

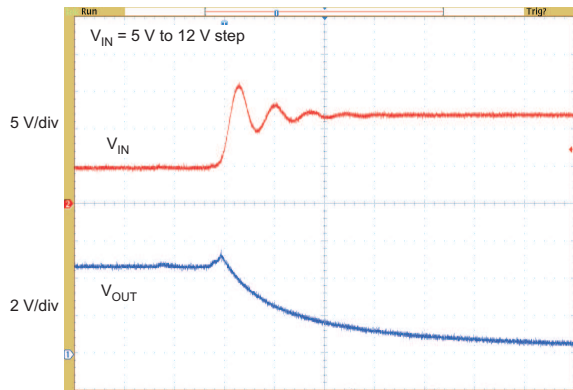

t - Time - 10  $\mu\text{s}$ /div

Figure 4.

**OVP RESPONSE FOR INPUT STEP**

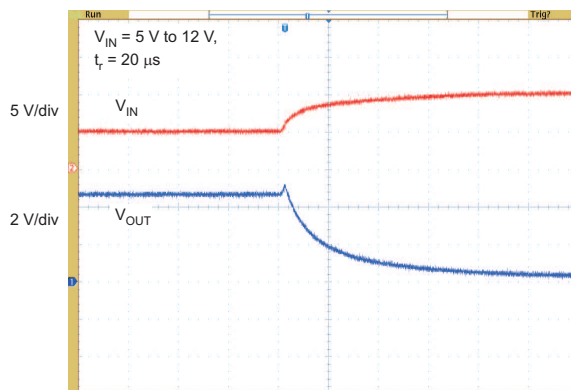

t - Time - 20  $\mu\text{s}$ /div

Figure 5.

**RECOVERY FROM OVP**

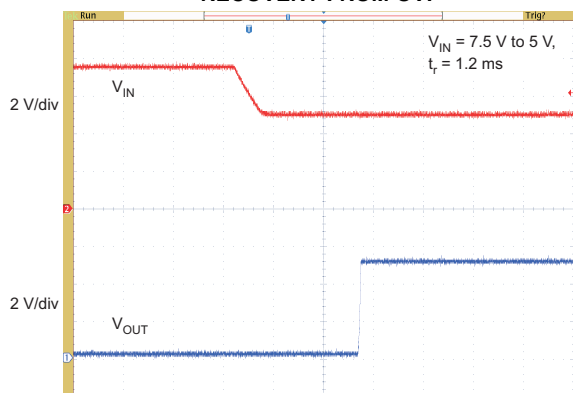

t - Time - 4 ms/div

Figure 6.

**OCP, POWERING UP INTO A SHORT CIRCUIT ON OUT, COUNTER COUNTS TO 15 BEFORE SWITCHING OFF THE DEVICE**

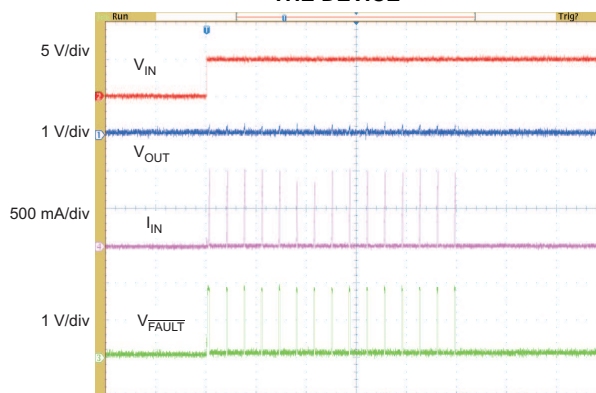

t - Time - 200 ms/div

Figure 7.

TYPICAL OPERATING PERFORMANCE (continued)

OCP, ZOOM-IN ON THE FIRST CYCLE OF FIGURE 7

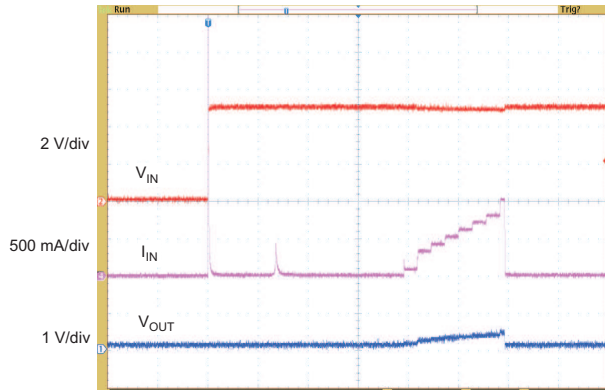

t - Time - 2 ms/div  
Figure 8.

ROUT SWITCHES FROM 6.6Ω TO 3.3Ω, SHOWS CURRENT LIMITING AND SOFT-STOP

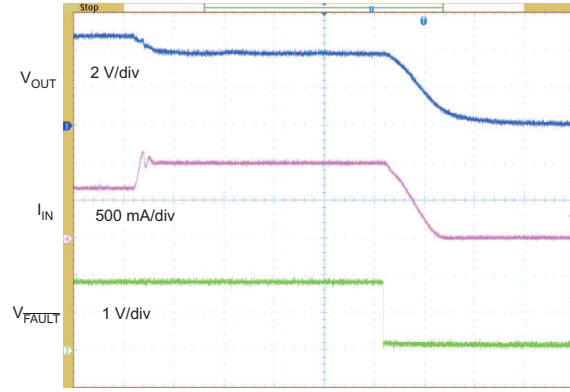

t - Time - 40 μs/div  
Figure 9.

BAT-OVP,  $V_{(VBAT)}$  STEPS FROM 4 V TO 4.5 V, SHOWS  $t_{DGL(BAT-OVP)}$  AND SOFT STOP

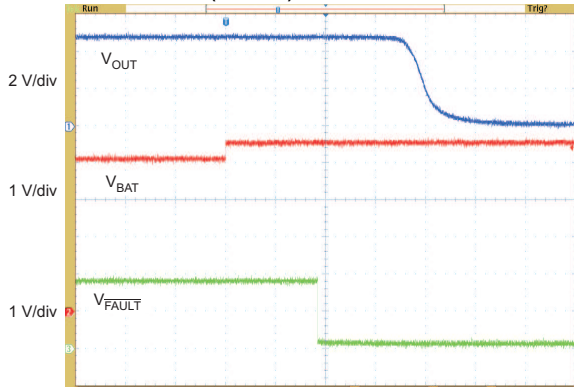

t - Time - 100 μs/div  
Figure 10.

BAT-OVP,  $V_{(VBAT)}$  CYCLES BETWEEN 4 V AND 4.5 V, SHOWS BAT-OVP COUNTER

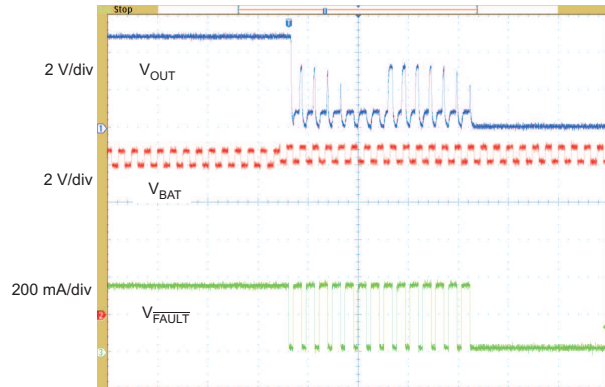

t - Time - 4 ms/div  
Figure 11.

INPUT VOLTAGE RAMP-UP / RAMP-DOWN  
bq24313

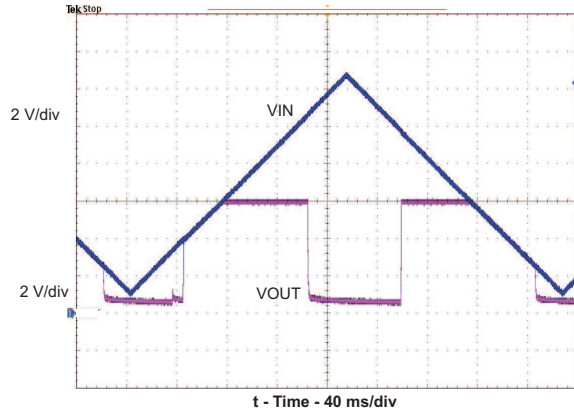

Figure 12.

UNDERVOLTAGE LOCKOUT  
VS  
FREE-AIR TEMPERATURE

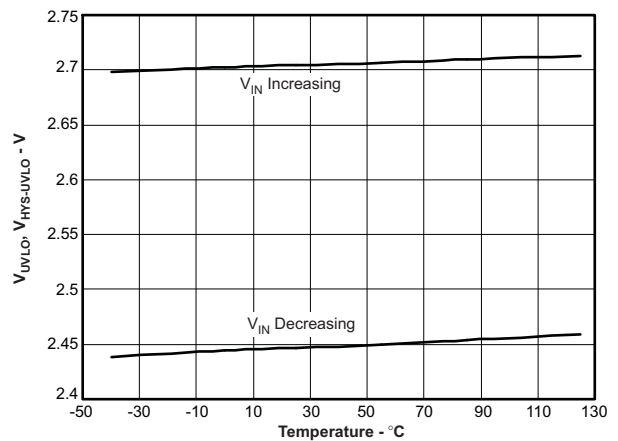

Figure 13.

TYPICAL OPERATING PERFORMANCE (continued)

DROPOUT VOLTAGE (IN to OUT)  
vs  
FREE-AIR TEMPERATURE

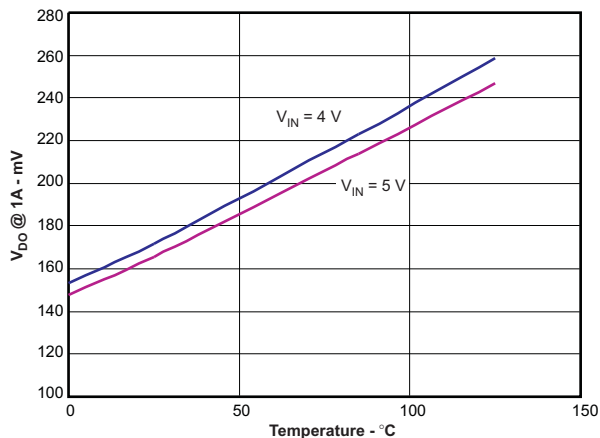

Figure 14.

OVERVOLTAGE PROTECTION THRESHOLD  
vs  
FREE-AIR TEMPERATURE  
bq24313

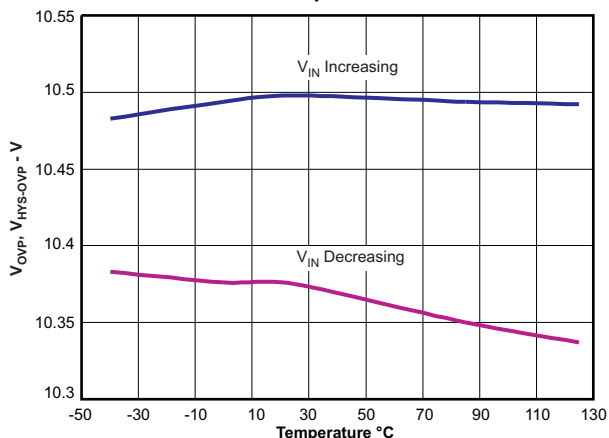

Figure 15.

OVERVOLTAGE THRESHOLD PROTECTION  
vs  
FREE-AIR TEMPERATURE  
bq24315

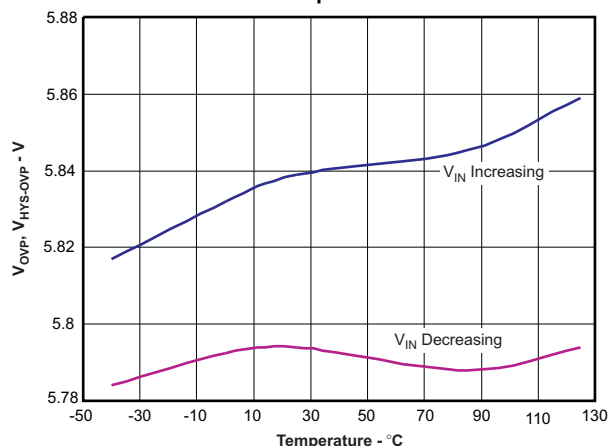

Figure 16.

INPUT OVERCURRENT PROTECTION  
vs  
ILIM RESISTANCE

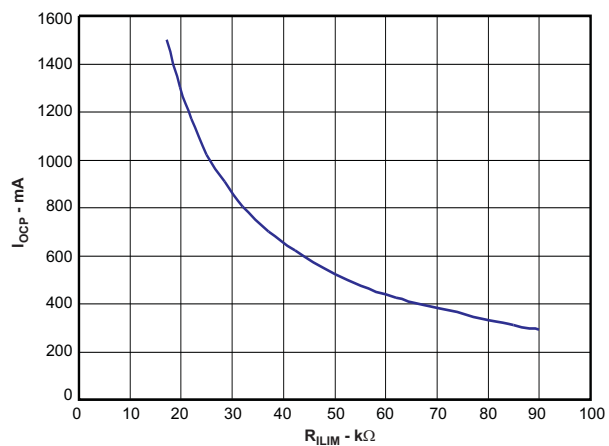

Figure 17.

TYPICAL OPERATING PERFORMANCE (continued)

INPUT OVERCURRENT PROTECTION  
vs  
FREE-AIR TEMPERATURE

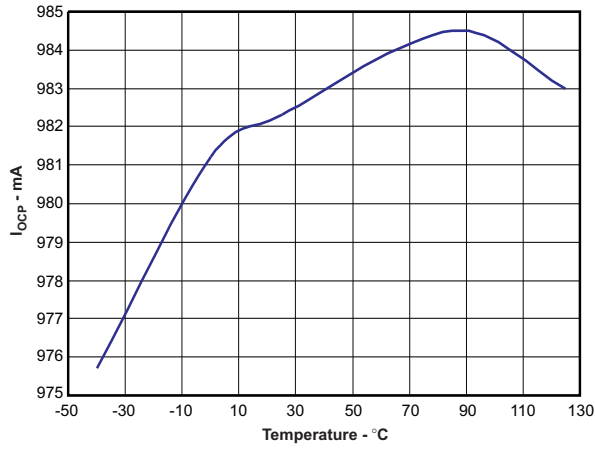

Figure 18.

BATTERY OVERVOLTAGE PROTECTION  
vs  
FREE-AIR TEMPERATURE

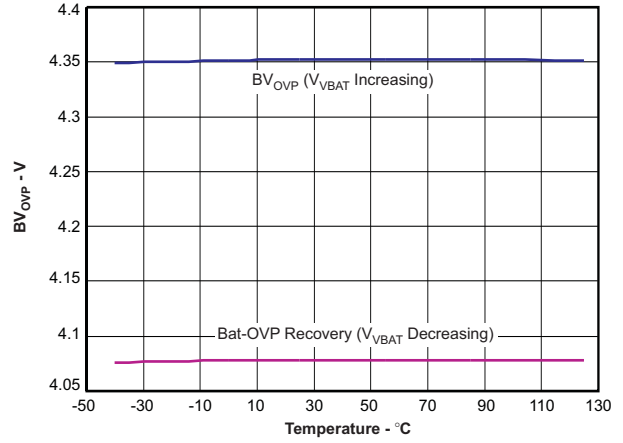

Figure 19.

LEAKAGE CURRENT (VBAT Pin)  
vs  
FREE-AIR TEMPERATURE

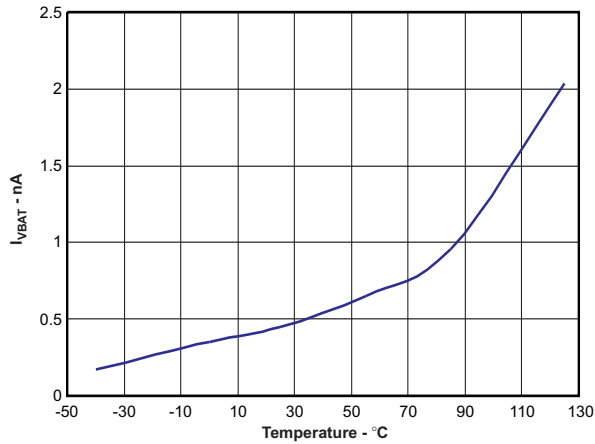

Figure 20.

SUPPLY CURRENT  
vs  
INPUT VOLTAGE

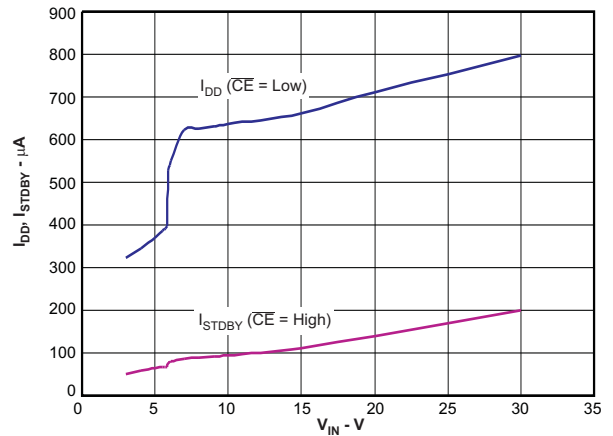

Figure 21.

## TYPICAL APPLICATION CIRCUIT

 $V_{OVP} = 5.85V$ ,  $I_{OCP} = 1000mA$ ,  $BV_{OVP} = 4.35V$ 

Figure 22.

## DETAILED FUNCTIONAL DESCRIPTION

The bq24313 and bq24315 are integrated circuits designed to provide protection to Li-ion batteries from failures of the charging circuit. The IC continuously monitors the input voltage, the input current and the battery voltage. For an input overvoltage condition, the IC immediately removes power from the charging circuit by turning off an internal switch. For an overcurrent condition, it limits the system current at the threshold value, and if the overcurrent persists, switches the pass element OFF after a blanking period. If the battery voltage rises to an unsafe level, the IC disconnects power from the charging circuit until the battery voltage returns to an acceptable value. Additionally, the IC also monitors its own die temperature and switches off if it exceeds 140°C. The input overcurrent threshold is user-programmable. The IC can be controlled by a processor, and also provides status information about fault conditions to the host.

### POWER DOWN

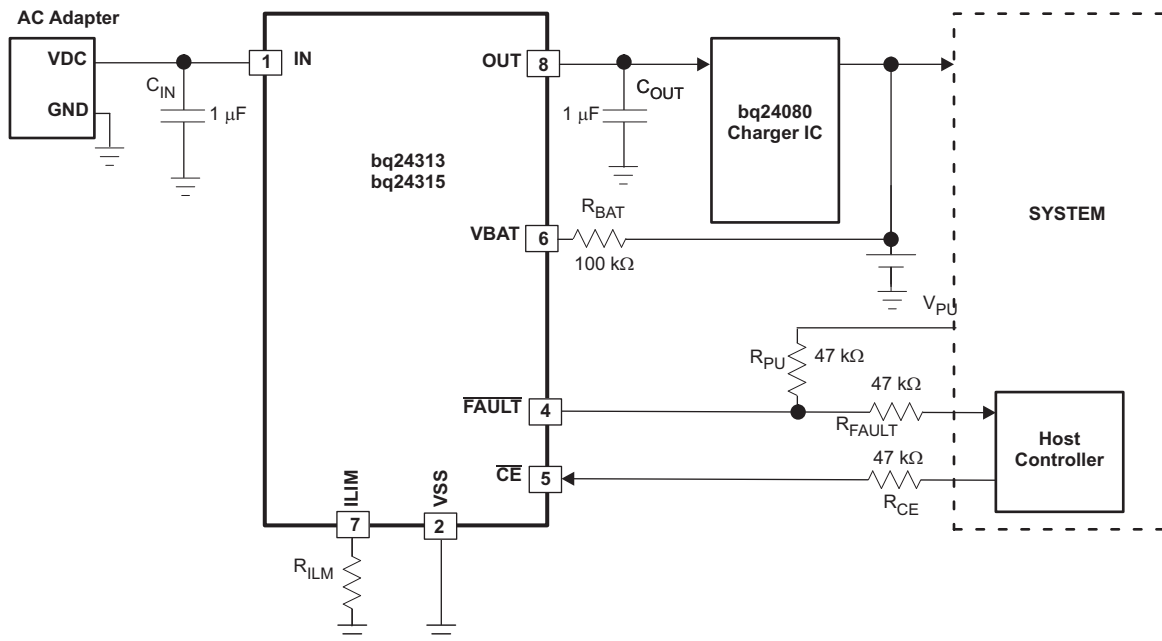
The device remains in power down mode when the input voltage at the IN pin is below the undervoltage threshold UVLO. The FET Q1 connected between IN and OUT pins is off, and the status output,  $\overline{FAULT}$ , is set to Hi-Z.

### POWER-ON RESET

The device resets when the input voltage at the IN pin exceeds the UVLO threshold. All internal counters and other circuit blocks are reset. The IC then waits for duration  $t_{DGL(PGOOD)}$  for the input voltage to stabilize. If, after  $t_{DGL(PGOOD)}$ , the input voltage and battery voltage are safe, FET Q1 is turned ON. The IC has a soft-start feature to control the inrush current. The soft-start minimizes the ringing at the input (the ringing occurs because the parasitic inductance of the adapter cable and the input bypass capacitor form a resonant circuit). Because of the deglitch time at power-on, if the input voltage rises rapidly to beyond the OVP threshold, the device will not switch on at all, instead it will go into protection mode and indicate a fault on the FAULT pin.

### OPERATION

The device continuously monitors the input voltage, the input current, and the battery voltage as described in detail in the following sections.

## Input Overvoltage Protection

While the input voltage is less than  $V_{O(REG)}$ , the output voltage tracks the input voltage (less the drop due to the  $R_{DS(on)}$  of Q1). When the input voltage is between  $V_{O(REG)}$  and  $V_{OVP}$ , the device functions as a linear regulator and regulates the output voltage to 5.5V. If the input voltage rises above  $V_{OVP}$ , the internal FET Q1 is turned off, removing power to the output. The response is rapid, with the FET turning off in less than a microsecond. The  $\overline{FAULT}$  pin is driven low. When the input voltage returns below  $V_{OVP} - V_{hys(OVP)}$  (but is still above UVLO), the FET Q1 is turned on again after a deglitch time of  $t_{ON(OVP)}$  to ensure that the input supply has stabilized.

## Input Overcurrent Protection

The overcurrent threshold is programmed by a resistor  $R_{(ILIM)}$  connected from the ILIM pin to VSS. Figure 17 shows the OCP threshold as a function of  $R_{(ILIM)}$ , and may be approximated by the following equation:  $I_{OCP} = 25 \div R_{(ILIM)}$  (current in A, resistance in k $\Omega$ )

If the load current tries to exceed the  $I_{OCP}$  threshold, the device limits the current for a blanking duration of  $t_{BLANK(OCP)}$ . If the load current returns to less than  $I_{OCP}$  before  $t_{BLANK(OCP)}$  times out, the device continues to operate. However, if the overcurrent situation persists for  $t_{BLANK(OCP)}$ , the FET Q1 is turned off for a duration of  $t_{REC(OCP)}$ , and the  $\overline{FAULT}$  pin is driven low. The FET is then turned on again after  $t_{REC(OCP)}$  and the current is monitored all over again. Each time an OCP fault occurs, an internal counter is incremented. If 15 OCP faults occur in one charge cycle, the FET is turned off permanently. The counter is cleared either by removing and re-applying input power, or by disabling and re-enabling the device with the  $\overline{CE}$  pin.

To prevent the input voltage from spiking up due to the inductance of the input cable, Q1 is turned off slowly, resulting in a “soft-stop”.

## Battery Overvoltage Protection

The battery overvoltage threshold  $BV_{OVP}$  is internally set to 4.35V. If the battery voltage exceeds the  $BV_{OVP}$  threshold, the FET Q1 is turned off, and the  $\overline{FAULT}$  pin is driven low. The FET is turned back on once the battery voltage drops to  $BV_{OVP} - V_{hys(Bovp)}$ . Each time a battery overvoltage fault occurs, an internal counter is incremented. If 15 such faults occur in one charge cycle, the FET is turned off permanently. The counter is cleared either by removing and re-applying input power, or by disabling and re-enabling the device with the  $\overline{CE}$  pin. For a battery overvoltage fault, Q1 is gradually switched OFF.

## Thermal Protection

If the junction temperature of the device exceeds  $T_{J(OFF)}$ , the FET Q1 is turned off, and the  $\overline{FAULT}$  pin is driven low. The FET is turned back on when the junction temperature falls below  $T_{J(OFF)} - T_{J(OFF-HYS)}$ .

## Enable Function

The IC has an enable pin which can be used to enable or disable the device. When the  $\overline{CE}$  pin is driven high, the internal FET is turned off. When the  $\overline{CE}$  pin is low, the FET is turned on if other conditions are safe. The OCP counter and the Bat-OVP counter are both reset when the device is disabled and re-enabled. The  $\overline{CE}$  pin has an internal pull-down resistor and can be left floating. Note that the  $\overline{FAULT}$  pin functionality is also disabled when the  $\overline{CE}$  pin is high.

## Fault Indication

The  $\overline{FAULT}$  pin is an active-low open-drain output. It is in a high-impedance state when operating conditions are safe, or when the device is disabled by setting  $\overline{CE}$  high. With  $\overline{CE}$  low, the  $\overline{FAULT}$  pin goes low whenever any of these events occurs:

- Input overvoltage
- Input overcurrent
- Battery overvoltage
- IC Overtemperature

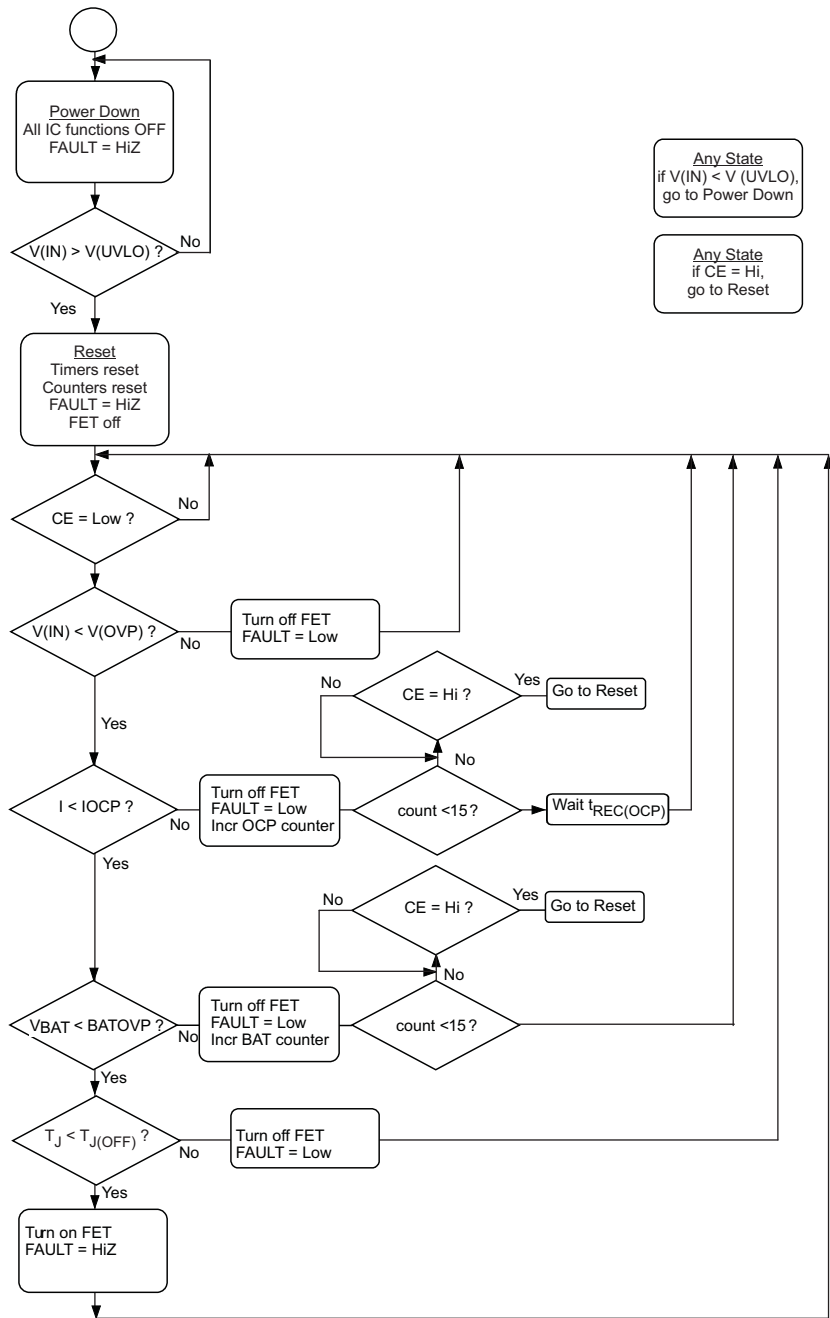

Figure 23. Flow Diagram

## APPLICATION INFORMATION (WITH REFERENCE TO [FIGURE 22](#))

### Selection of $R_{BAT}$

It is strongly recommended that the battery not be tied directly to the VBAT pin of the device, as under some failure modes of the IC, the voltage at the IN pin may appear on the VBAT pin. This voltage can be as high as 30V, and applying 30V to the battery in case of the failure of the bq24315 can be hazardous. Connecting the VBAT pin through  $R_{BAT}$  prevents a large current from flowing into the battery in case of a failure of the IC. In the interests of safety,  $R_{BAT}$  should have a high value. The problem with a large  $R_{BAT}$  is that the voltage drop across this resistor, due to the VBAT bias current  $I_{(VBAT)}$ , causes an error in the  $BV_{OVP}$  threshold. This error is over and above the tolerance on the nominal 4.35V  $BV_{OVP}$  threshold.

Choosing  $R_{BAT}$  in the range 100k $\Omega$  to 470k $\Omega$  is a good compromise. In the event of an IC failure, with  $R_{BAT}$  equal to 100k $\Omega$ , the maximum current flowing into the battery would be  $(30V - 3V) \div 100k\Omega = 246\mu A$ , which is low enough to be absorbed by the bias currents of the system components.  $R_{BAT}$  equal to 100k $\Omega$  results in a worst-case voltage drop of  $R_{BAT} \times I_{(VBAT)} = 1mV$ . This is negligible to compared to the internal tolerance of 50mV on  $BV_{OVP}$  threshold.

If the Bat-OVP function is not required, the VBAT pin should be connected to VSS.

### Selection of $R_{CE}$ , $R_{FAULT}$ , and $R_{PU}$

The  $\overline{CE}$  pin can be used to enable and disable the IC. If host control is not required, the  $\overline{CE}$  pin can be tied to ground or left un-connected, permanently enabling the device.

In applications where external control is required, the  $\overline{CE}$  pin can be controlled by a host processor. As in the case of the VBAT pin (see above), the  $\overline{CE}$  pin should be connected to the host GPIO pin through as large a resistor as possible. The limitation on the resistor value is that the minimum  $V_{OH}$  of the host GPIO pin less the drop across the resistor should be greater than  $V_{IH}$  of the bq24315  $\overline{CE}$  pin. The drop across the resistor is given by  $R_{CE} \times I_{IH}$ .

The  $\overline{FAULT}$  pin is an open-drain output that goes low during OV, OC, battery-OV, and OT events. If the application does not require monitoring of the  $\overline{FAULT}$  pin, it can be left unconnected. But if the  $\overline{FAULT}$  pin has to be monitored, it should be pulled high externally through  $R_{PU}$ , and connected to the host through  $R_{FAULT}$ .  $R_{FAULT}$  prevents damage to the host controller if the bq24315 fails (see above). The resistors should be of high value, in practice values between 22k $\Omega$  and 100k $\Omega$  should be sufficient.

### Selection of Input and Output Bypass Capacitors

The input capacitor  $C_{IN}$  in [Figure 22](#) is for decoupling, and serves an important purpose. Whenever there is a step change downwards in the system load current, the inductance of the input cable causes the input voltage to spike up.  $C_{IN}$  prevents the input voltage from overshooting to dangerous levels. It is recommended that a ceramic capacitor of at least 1 $\mu F$  be used at the input of the device. It should be located in close proximity to the IN pin.

$C_{OUT}$  in [Figure 22](#) is also important: If a fast (< 1 $\mu s$  rise time) overvoltage transient occurs at the input, the current that charges  $C_{OUT}$  causes the device's current-limiting loop to start, reducing the gate-drive to FET Q1. This results in improved performance for input overvoltage protection.  $C_{OUT}$  should also be a ceramic capacitor of at least 1 $\mu F$ , located close to the OUT pin.  $C_{OUT}$  also serves as the input decoupling capacitor for the charging circuit downstream of the protection IC.

### Powering Accessories

In some applications, the equipment that the protection IC resides in may be required to provide power to an accessory (e.g. a cellphone may power a headset or an external memory card) through the same connector pins that are used by the adapter for charging. [Figure 24](#) and [Figure 25](#) illustrate typical charging and accessory-powering scenarios:

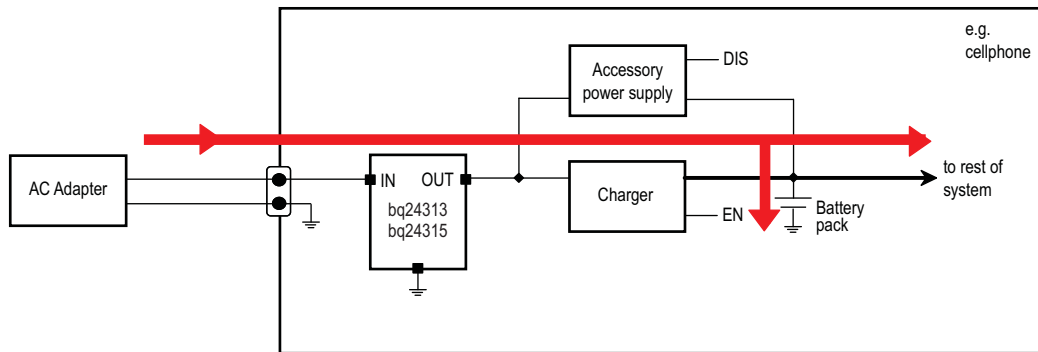

**Figure 24. Charging - The Red Arrows Show the Direction of Current Flow**

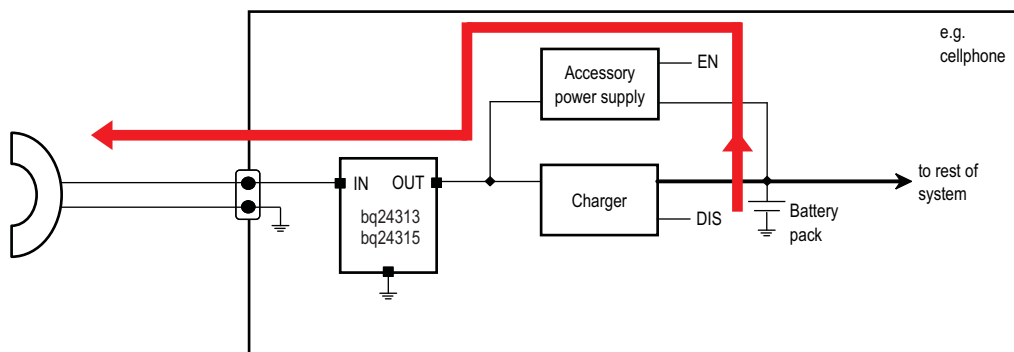

**Figure 25. Powering an Accessory - The Red Arrows Show the Direction of Current Flow**

In the second case, when power is being delivered to an accessory, the bq24313/bq24315 device is required to support current flow from the OUT pin to the IN pin.

If  $V_{OUT} > UVLO + 0.7V$ , FET Q1 is turned on, and the reverse current does not flow through the diode but through Q1. Q1 remains ON as long as  $V_{OUT} > UVLO - V_{hys}(UVLO) + R_{DS(on)} \times I_{(ACCESSORY)}$ . Within this voltage range, the reverse current capability is the same as the forward capability, 1.5A. It should be noted that there is no overcurrent protection in this direction.

### PCB Layout Guidelines:

- This device is a protection device, and is meant to protect down-stream circuitry from hazardous voltages. Potentially, high voltages may be applied to this IC. It has to be ensured that the edge-to-edge clearances of PCB traces satisfy the design rules for high voltages.
- The device uses SON packages with a PowerPAD™. For good thermal performance, the PowerPAD should be thermally coupled with the PCB ground plane. In most applications, this will require a copper pad directly under the IC. This copper pad should be connected to the ground plane with an array of thermal vias.
- $C_{IN}$  and  $C_{OUT}$  should be located close to the IC. Other components like  $R_{(ILIM)}$  and  $R_{BAT}$  should also be located close to the IC.

**PACKAGING INFORMATION**

Orderable Device	Status (1)	Package Type	Package Drawing	Pins	Package Qty	Eco Plan (2)	Lead/Ball Finish (6)	MSL Peak Temp (3)	Op Temp (°C)	Device Marking (4/5)	Samples
BQ24313DSGR	ACTIVE	WSO	DSG	8	3000	Green (RoHS & no Sb/Br)	CU NIPDAU	Level-2-260C-1 YEAR	-40 to 125	NXQ	<a href="#">Samples</a>
BQ24313DSGT	ACTIVE	WSO	DSG	8	250	Green (RoHS & no Sb/Br)	CU NIPDAU	Level-2-260C-1 YEAR	-40 to 125	NXQ	<a href="#">Samples</a>
BQ24315DSGR	ACTIVE	WSO	DSG	8	3000	Green (RoHS & no Sb/Br)	CU NIPDAU	Level-2-260C-1 YEAR	-40 to 125	CGM	<a href="#">Samples</a>
BQ24315DSGT	ACTIVE	WSO	DSG	8	250	Green (RoHS & no Sb/Br)	CU NIPDAU	Level-2-260C-1 YEAR	-40 to 125	CGM	<a href="#">Samples</a>

(1) The marketing status values are defined as follows:

**ACTIVE:** Product device recommended for new designs.

**LIFEBUY:** TI has announced that the device will be discontinued, and a lifetime-buy period is in effect.

**NRND:** Not recommended for new designs. Device is in production to support existing customers, but TI does not recommend using this part in a new design.

**PREVIEW:** Device has been announced but is not in production. Samples may or may not be available.

**OBSELETE:** TI has discontinued the production of the device.

(2) Eco Plan - The planned eco-friendly classification: Pb-Free (RoHS), Pb-Free (RoHS Exempt), or Green (RoHS & no Sb/Br) - please check <http://www.ti.com/productcontent> for the latest availability information and additional product content details.

**TBD:** The Pb-Free/Green conversion plan has not been defined.

**Pb-Free (RoHS):** TI's terms "Lead-Free" or "Pb-Free" mean semiconductor products that are compatible with the current RoHS requirements for all 6 substances, including the requirement that lead not exceed 0.1% by weight in homogeneous materials. Where designed to be soldered at high temperatures, TI Pb-Free products are suitable for use in specified lead-free processes.

**Pb-Free (RoHS Exempt):** This component has a RoHS exemption for either 1) lead-based flip-chip solder bumps used between the die and package, or 2) lead-based die adhesive used between the die and leadframe. The component is otherwise considered Pb-Free (RoHS compatible) as defined above.

**Green (RoHS & no Sb/Br):** TI defines "Green" to mean Pb-Free (RoHS compatible), and free of Bromine (Br) and Antimony (Sb) based flame retardants (Br or Sb do not exceed 0.1% by weight in homogeneous material)

(3) MSL, Peak Temp. - The Moisture Sensitivity Level rating according to the JEDEC industry standard classifications, and peak solder temperature.

(4) There may be additional marking, which relates to the logo, the lot trace code information, or the environmental category on the device.

(5) Multiple Device Markings will be inside parentheses. Only one Device Marking contained in parentheses and separated by a "~" will appear on a device. If a line is indented then it is a continuation of the previous line and the two combined represent the entire Device Marking for that device.

(6) Lead/Ball Finish - Orderable Devices may have multiple material finish options. Finish options are separated by a vertical ruled line. Lead/Ball Finish values may wrap to two lines if the finish value exceeds the maximum column width.

**Important Information and Disclaimer:**The information provided on this page represents TI's knowledge and belief as of the date that it is provided. TI bases its knowledge and belief on information provided by third parties, and makes no representation or warranty as to the accuracy of such information. Efforts are underway to better integrate information from third parties. TI has taken and continues to take reasonable steps to provide representative and accurate information but may not have conducted destructive testing or chemical analysis on incoming materials and chemicals. TI and TI suppliers consider certain information to be proprietary, and thus CAS numbers and other limited information may not be available for release.

In no event shall TI's liability arising out of such information exceed the total purchase price of the TI part(s) at issue in this document sold by TI to Customer on an annual basis.

## TAPE AND REEL INFORMATION



### QUADRANT ASSIGNMENTS FOR PIN 1 ORIENTATION IN TAPE



\*All dimensions are nominal

Device	Package Type	Package Drawing	Pins	SPQ	Reel Diameter (mm)	Reel Width W1 (mm)	A0 (mm)	B0 (mm)	K0 (mm)	P1 (mm)	W (mm)	Pin1 Quadrant
BQ24313DSGR	WSON	DSG	8	3000	180.0	8.4	2.2	2.2	1.2	4.0	8.0	Q2
BQ24313DSGR	WSON	DSG	8	3000	178.0	8.4	2.25	2.25	1.0	4.0	8.0	Q2
BQ24313DSGT	WSON	DSG	8	250	179.0	8.4	2.2	2.2	1.2	4.0	8.0	Q2
BQ24313DSGT	WSON	DSG	8	250	178.0	8.4	2.25	2.25	1.0	4.0	8.0	Q2
BQ24315DSGR	WSON	DSG	8	3000	178.0	8.4	2.25	2.25	1.0	4.0	8.0	Q2
BQ24315DSGT	WSON	DSG	8	250	178.0	8.4	2.25	2.25	1.0	4.0	8.0	Q2

**TAPE AND REEL BOX DIMENSIONS**

\*All dimensions are nominal

Device	Package Type	Package Drawing	Pins	SPQ	Length (mm)	Width (mm)	Height (mm)
BQ24313DSGR	WSON	DSG	8	3000	195.0	200.0	45.0
BQ24313DSGR	WSON	DSG	8	3000	205.0	200.0	33.0
BQ24313DSGT	WSON	DSG	8	250	195.0	200.0	45.0
BQ24313DSGT	WSON	DSG	8	250	205.0	200.0	33.0
BQ24315DSGR	WSON	DSG	8	3000	205.0	200.0	33.0
BQ24315DSGT	WSON	DSG	8	250	205.0	200.0	33.0

## GENERIC PACKAGE VIEW

**DSG 8**

**WSON - 0.8 mm max height**

2 x 2, 0.5 mm pitch

PLASTIC SMALL OUTLINE - NO LEAD

This image is a representation of the package family, actual package may vary.  
Refer to the product data sheet for package details.

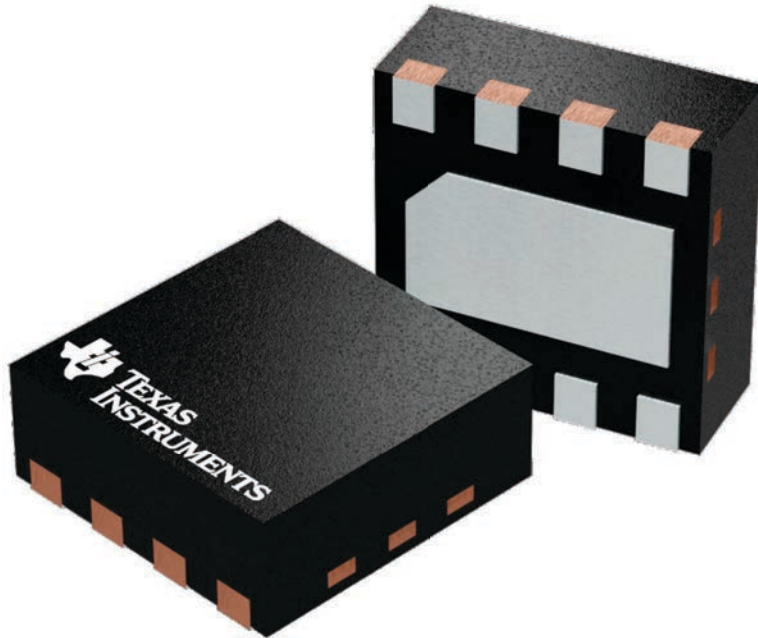

4224783/A

# DSG0008A

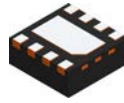

# PACKAGE OUTLINE

## WSON - 0.8 mm max height

PLASTIC SMALL OUTLINE - NO LEAD

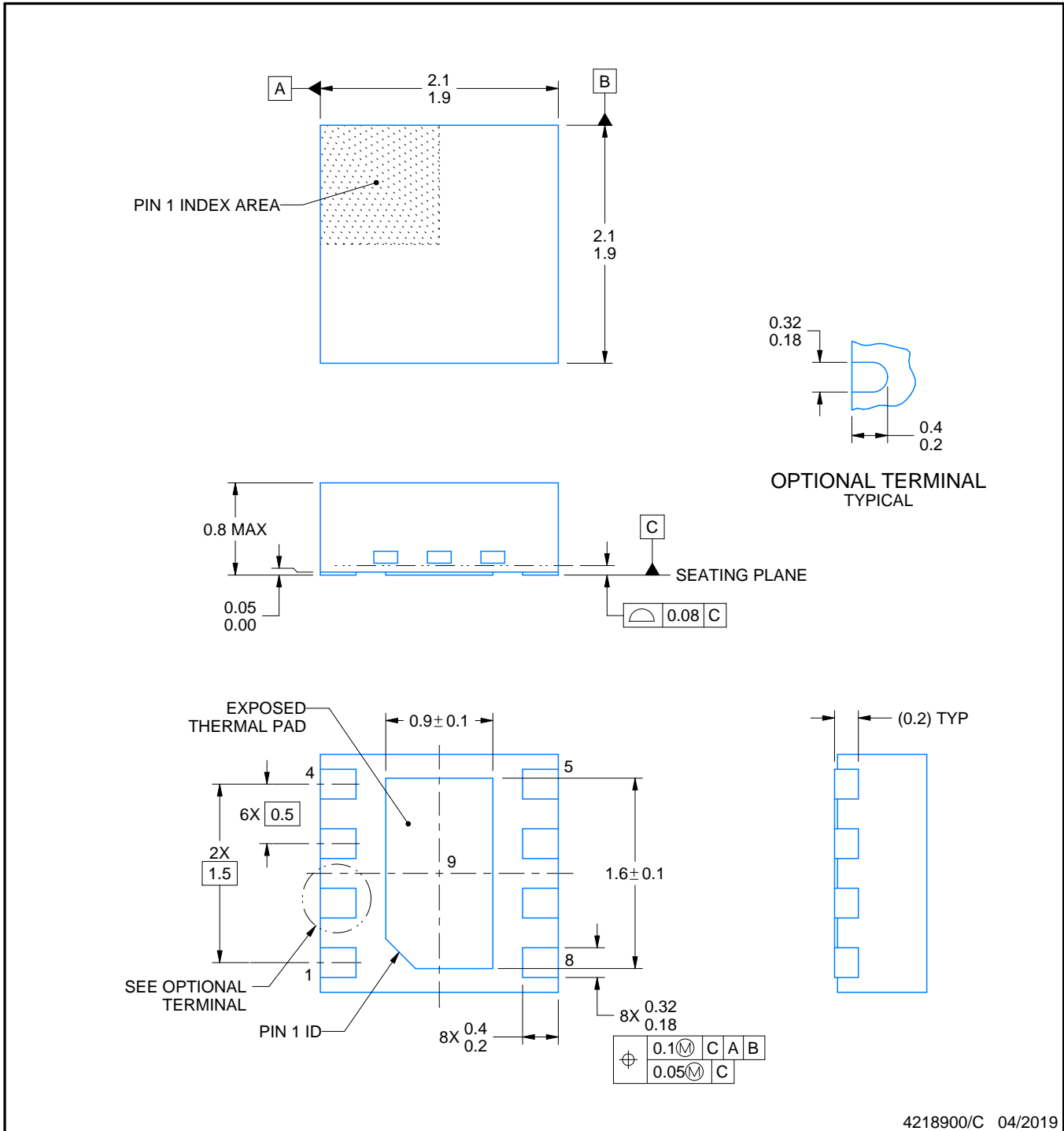

4218900/C 04/2019

### NOTES:

1. All linear dimensions are in millimeters. Any dimensions in parenthesis are for reference only. Dimensioning and tolerancing per ASME Y14.5M.
2. This drawing is subject to change without notice.
3. The package thermal pad must be soldered to the printed circuit board for thermal and mechanical performance.



# EXAMPLE STENCIL DESIGN

DSG0008A

WSON - 0.8 mm max height

PLASTIC SMALL OUTLINE - NO LEAD

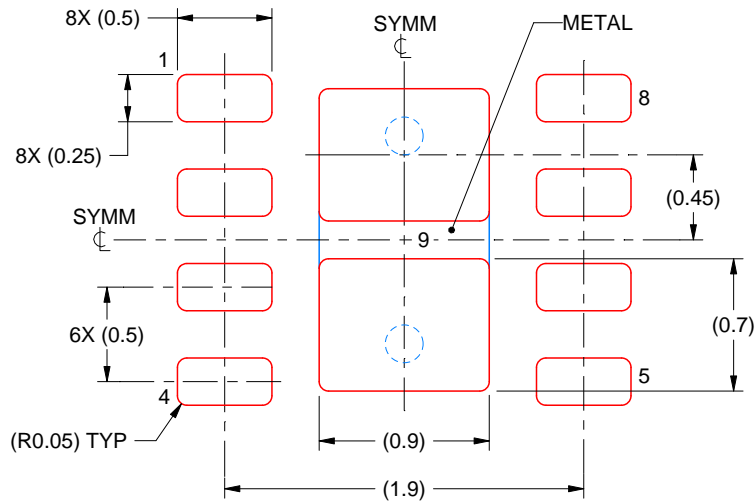

SOLDER PASTE EXAMPLE  
BASED ON 0.125 mm THICK STENCIL

EXPOSED PAD 9:  
87% PRINTED SOLDER COVERAGE BY AREA UNDER PACKAGE  
SCALE:25X

4218900/C 04/2019

NOTES: (continued)

6. Laser cutting apertures with trapezoidal walls and rounded corners may offer better paste release. IPC-7525 may have alternate design recommendations.

## IMPORTANT NOTICE AND DISCLAIMER

TI PROVIDES TECHNICAL AND RELIABILITY DATA (INCLUDING DATASHEETS), DESIGN RESOURCES (INCLUDING REFERENCE DESIGNS), APPLICATION OR OTHER DESIGN ADVICE, WEB TOOLS, SAFETY INFORMATION, AND OTHER RESOURCES "AS IS" AND WITH ALL FAULTS, AND DISCLAIMS ALL WARRANTIES, EXPRESS AND IMPLIED, INCLUDING WITHOUT LIMITATION ANY IMPLIED WARRANTIES OF MERCHANTABILITY, FITNESS FOR A PARTICULAR PURPOSE OR NON-INFRINGEMENT OF THIRD PARTY INTELLECTUAL PROPERTY RIGHTS.

These resources are intended for skilled developers designing with TI products. You are solely responsible for (1) selecting the appropriate TI products for your application, (2) designing, validating and testing your application, and (3) ensuring your application meets applicable standards, and any other safety, security, or other requirements. These resources are subject to change without notice. TI grants you permission to use these resources only for development of an application that uses the TI products described in the resource. Other reproduction and display of these resources is prohibited. No license is granted to any other TI intellectual property right or to any third party intellectual property right. TI disclaims responsibility for, and you will fully indemnify TI and its representatives against, any claims, damages, costs, losses, and liabilities arising out of your use of these resources.

TI's products are provided subject to TI's Terms of Sale ([www.ti.com/legal/termsofsale.html](http://www.ti.com/legal/termsofsale.html)) or other applicable terms available either on [ti.com](http://ti.com) or provided in conjunction with such TI products. TI's provision of these resources does not expand or otherwise alter TI's applicable warranties or warranty disclaimers for TI products.

Mailing Address: Texas Instruments, Post Office Box 655303, Dallas, Texas 75265  
Copyright © 2019, Texas Instruments Incorporated

## Looking for pricing, stock, or lifecycle information?

Click below to explore more details on WIN SOURCE:

 [View BQ24315DSGR](#) on WIN SOURCE

 [Texas Instruments](#) Information

## Optimize Your Supply Chain with WIN SOURCE Solutions

-  Global Sourcing Solution
-  Obsolete Management
-  Cost Control Management
-  Shortage Management
-  Alternative Solution
-  Excess Inventory Management