



**THE DATASHEET OF
TS3A24159YZPR**



TS3A24159 0.3-Ω 2-Channel SPDT Bidirectional Analog Switch

Dual-Channel 2:1 Multiplexer and Demultiplexer

1 Features

- Specified break-before-make switching
- Low ON-state resistance (0.3 Ω maximum)
- Low charge injection
- Excellent ON-state resistance matching
- Low total harmonic distortion (THD)
- 1.65-V to 3.6-V single-supply operation
- Control inputs are 1.8-V logic compatible
- Latch-up performance exceeds 100 mA per JESD 78, Class II
- ESD performance tested per JESD 22
 - 2000-V Human-Body Model (A114-B, Class II)
 - 1000-V Charged-Device Model (C101)

2 Applications

- [Cell phones](#)
- Personal digital assistant (PDAs)
- [Portable instrumentation](#)
- [Audio and video signal routing](#)
- [Low-voltage data-acquisition systems](#)
- [Communication circuits](#)
- [Modems](#)
- Hard drives
- [Computer peripherals](#)
- Wireless terminals and peripherals

3 Description

The TS3A24159 is a 2-channel single-pole double-throw (SPDT) bidirectional analog switch that is designed to operate from 1.65 V to 3.6 V. It offers low ON-state resistance and excellent ON-state resistance matching with the break-before-make feature, to prevent signal distortion during the transferring of a signal from one channel to another. The device has excellent total harmonic distortion (THD) performance, low ON-state resistance, and consumes very low power. These are some of the features that make this device suitable for a variety of markets and many different applications.

Device Information⁽¹⁾

PART NUMBER	PACKAGE	BODY SIZE (NOM)
TS3A24159	VSSOP (10)	3.00 mm × 3.00 mm
	VSON (10)	3.00 mm × 3.00 mm
	DSBGA (10)	1.86 mm × 1.35 mm

(1) For all available packages, see the orderable addendum at the end of the data sheet.

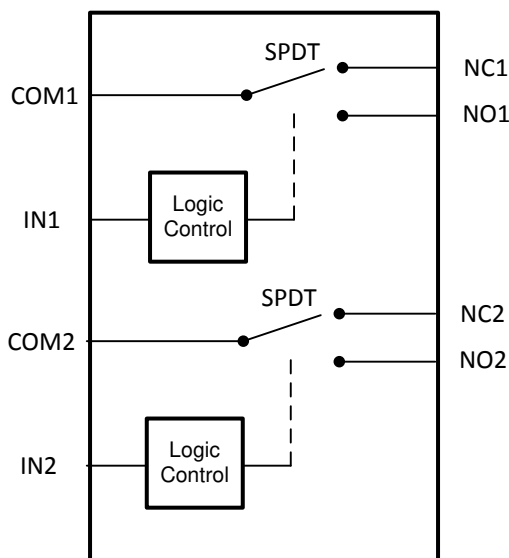

Functional Block Diagram



Table of Contents

1 Features	1	8.2 Functional Block Diagram.....	18
2 Applications	1	8.3 Feature Description.....	18
3 Description	1	8.4 Device Functional Modes.....	18
4 Revision History	2	9 Application and Implementation	19
5 Pin Configuration and Functions	3	9.1 Application Information.....	19
6 Specifications	5	9.2 Typical Application.....	19
6.1 Absolute Maximum Ratings.....	5	10 Power Supply Recommendations	20
6.2 ESD Ratings.....	5	11 Layout	21
6.3 Recommended Operating Conditions.....	5	11.1 Layout Guidelines.....	21
6.4 Thermal Information.....	6	11.2 Layout Example.....	21
6.5 Electrical Characteristics for 3-V Supply.....	6	12 Device and Documentation Support	22
6.6 Electrical Characteristics for 2.5-V Supply.....	7	12.1 Documentation Support.....	22
6.7 Electrical Characteristics for 1.8-V Supply.....	9	12.2 Receiving Notification of Documentation Updates.....	22
6.8 Switching Characteristics for a 3-V Supply.....	10	12.3 Support Resources.....	22
6.9 Switching Characteristics for a 2.5-V Supply.....	10	12.4 Trademarks.....	22
6.10 Switching Characteristics for a 1.8-V Supply.....	11	12.5 Electrostatic Discharge Caution.....	22
6.11 Typical Characteristics.....	12	12.6 Glossary.....	22
7 Parameter Measurement Information	14	13 Mechanical, Packaging, and Orderable Information	22
8 Detailed Description	18		
8.1 Overview.....	18		

4 Revision History

NOTE: Page numbers for previous revisions may differ from page numbers in the current version.

Changes from Revision G (February 2022) to Revision H (August 2022)	Page
• Changed the maximum V_{CC} from: 3.6 V to: 4 V	5
Changes from Revision F (September 2019) to Revision G (February 2022)	Page
• Updated the numbering format for tables, figures, and cross-references throughout the document.....	1
• Updated the part number in the <i>Detailed Design Procedure</i>	20
Changes from Revision E (March 2019) to Revision F (September 2019)	Page
• Changed the YZP package image view From: Top-Through View To: Bottom View.....	3
Changes from Revision D (July 2015) to Revision E (March 2019)	Page
• Changed the YZP package image and deleted the <i>YZP Package, Terminal Assignments</i> table.....	3
• Changed Turnon time V_{CC} (Full) value From: 2.3 V to 2.7 V To: 2.7 V to 3.6 V in <i>Switching Characteristics for a 3-V Supply</i>	10
• Changed Turnon time V_{CC} (Full) value From: 2.3 V to 2.7 V To: 2.7 V to 3.6 V in <i>Switching Characteristics for a 2.5-V Supply</i>	10
Changes from Revision C (February 2008) to Revision D (March 2015)	Page
• Added <i>Pin Configuration and Functions</i> section, <i>ESD Ratings</i> table, <i>Feature Description</i> section, <i>Device Functional Modes</i> , <i>Application and Implementation</i> section, <i>Power Supply Recommendations</i> section, <i>Layout</i> section, <i>Device and Documentation Support</i> section, and <i>Mechanical, Packaging, and Orderable Information</i> section	1
• Changed $V+$ to V_{CC} throughout the document to meet JEDEC standards.....	1

5 Pin Configuration and Functions

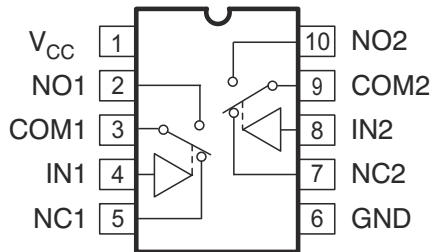

Figure 5-1. DGS Package, 10-Pin VSSOP (Top View)

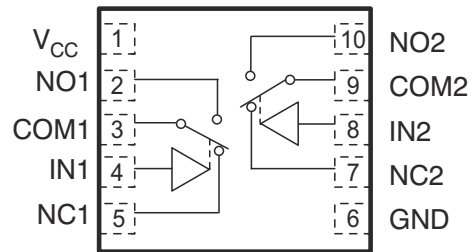

Figure 5-2. DRC Package, 10-Pin VSON (Top View)

Table 5-1. Pin Functions – VSSOP and VSON

PIN		TYPE ⁽¹⁾	DESCRIPTION
NO.	NAME		
1	V _{CC}	—	Power supply
2	NO1	I/O	Normally open signal path
3	COM1	I/O	Common signal path
4	IN1	I	Digital control to connect COM to NO or NC
5	NC1	I/O	Normally closed signal path
6	GND	—	Ground
7	NC2	I/O	Normally closed signal path
8	IN2	I	Digital control to connect COM to NO or NC
9	COM2	I/O	Common signal path
10	NO2	I/O	Normally open signal path

(1) I = input, O = output

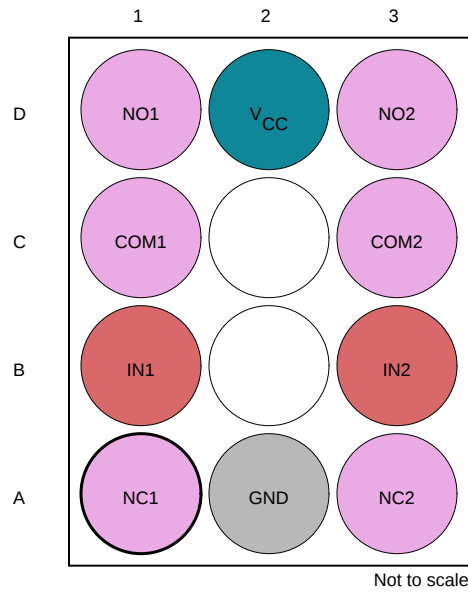

Figure 5-3. YZP Package, 10-Pin DSBGA (Bottom View)

Legend	
Input or Output	Input
Ground	Power

Table 5-2. Pin Functions – DSBGA

PIN		TYPE ⁽¹⁾	DESCRIPTION
NO.	NAME		
A1	NC1	I/O	Normally closed signal path
A2	GND	—	Ground
A3	NC2	I/O	Normally closed signal path
B1	IN1	I	Digital control to connect COM to NO or NC
B3	IN2	I	Digital control to connect COM to NO or NC
C1	COM1	I/O	Common signal path
C3	COM2	I/O	Common signal path
D1	NO1	I/O	Normally open signal path
D2	V _{CC}	—	Power supply
D3	NO2	I/O	Normally open signal path

(1) I = input, O = output

6 Specifications

6.1 Absolute Maximum Ratings

over operating free-air temperature range (unless otherwise noted) ⁽¹⁾ ⁽²⁾

			MIN	MAX	UNIT
V _{CC}	Supply voltage ⁽³⁾		-0.5	4	V
V _{NC} V _{NO} V _{COM}	Signal voltage ⁽³⁾ ⁽⁴⁾		-0.5	V _{CC} + 0.5	V
I _{I/O} K	Analog port diode current	V _{NC} , V _{NO} , V _{COM} < 0	-50	50	mA
I _{NC} I _{NO} I _{COM}	ON-state switch current	V _{NC} , V _{NO} , V _{COM} = 0 to V _{CC}	-300	300	mA
	ON-state peak switch current ⁽⁵⁾		-500	500	
V _{IN}	Digital input voltage		-0.5	3.6	V
I _{IK}	Digital input clamp current ⁽³⁾	V _I < 0	-50		mA
I _{CC}	Continuous current through V _{CC}			100	mA
I _{GND}	Continuous current through GND		-100		mA
T _{stg}	Storage temperature		-65	150	°C

- (1) Stresses beyond those listed under *Absolute Maximum Ratings* may cause permanent damage to the device. These are stress ratings only, which do not imply functional operation of the device at these or any other conditions beyond those indicated under *Recommended Operating Conditions*. Exposure to absolute-maximum-rated conditions for extended periods may affect device reliability.
- (2) The algebraic convention, whereby the most negative value is a minimum and the most positive value is a maximum.
- (3) All voltages are with respect to ground, unless otherwise specified.
- (4) This value is limited to 5.5 V maximum.
- (5) Pulse at 1-ms duration <10% duty cycle.

6.2 ESD Ratings

		VALUE	UNIT
V _(ESD)	Electrostatic discharge	Human body model (HBM), per ANSI/ESDA/JEDEC JS-001 ⁽¹⁾	2000
		Charged-device model (CDM), per JEDEC specification JESD22-C101 or ANSI/ESDA/JEDEC JS-002 ⁽²⁾	1000

- (1) JEDEC document JEP155 states that 500-V HBM allows safe manufacturing with a standard ESD control process.
- (2) JEDEC document JEP157 states that 250-V CDM allows safe manufacturing with a standard ESD control process.

6.3 Recommended Operating Conditions

over operating free-air temperature range (unless otherwise noted)

		MIN	MAX	UNIT
V _{CC}	Supply Voltage	1.65	3.6	V
V _{NC} V _{NO} V _{COM}	Signal Voltage	0	V _{CC}	V
V _{IN}	Digital Input Voltage	0	V _{CC}	V

6.4 Thermal Information

THERMAL METRIC ⁽¹⁾		TS3A24159			UNIT
		DGS (VSSOP)	DRC (VSON)	YZP (DSBGA)	
		10 PINS	10 PINS	10 PINS	
R _{θJA}	Junction-to-ambient thermal resistance	154	49.4	90.9	°C/W
R _{θJC(top)}	Junction-to-case (top) thermal resistance	37.9	71.2	0.3	°C/W
R _{θJB}	Junction-to-board thermal resistance	83.6	23.8	8.3	°C/W
ψ _{JT}	Junction-to-top characterization parameter	1.4	2.2	3.2	°C/W
ψ _{JB}	Junction-to-board characterization parameter	82.2	23.8	8.3	°C/W
R _{θJC(bot)}	Junction-to-case (bottom) thermal resistance	N/A	6.1	N/A	°C/W

(1) For more information about traditional and new thermal metrics, see the [Semiconductor and IC Package Thermal Metrics](#) application report.

6.5 Electrical Characteristics for 3-V Supply

V_{CC} = 2.7 V to 3.6 V, T_A = –40°C to 85°C (unless otherwise noted) ⁽¹⁾

PARAMETER	TEST CONDITIONS	T _A	V _{CC}	MIN	TYP	MAX	UNIT	
ANALOG SWITCH								
Analog signal range	V _{COM} , V _{NO} , V _{NC}			0		V _{CC}	V	
Peak ON resistance	r _{peak} 0 ≤ (V _{NO} or V _{NC}) ≤ V _{CC} , I _{COM} = –100 mA,	25°C Full	2.7 V		0.2	0.3 0.35	Ω	
ON-state resistance	r _{on} V _{NO} or V _{NC} = 2 V, I _{COM} = –100 mA,	25°C Full	2.7 V		0.26	0.3 0.34	Ω	
ON-state resistance match between channels	Δr _{on} V _{NO} or V _{NC} = 2 V, 0.8 V, I _{COM} = –100 mA,	25°C Full	2.7 V		0.01	0.05 0.05	Ω	
ON-state resistance flatness	r _{on(flat)} 0 ≤ (V _{NO} or V _{NC}) ≤ V _{CC} , I _{COM} = –100 mA, V _{NO} or V _{NC} = 2 V, 0.8 V, I _{COM} = –100 mA,	25°C Full	2.7 V		0.13	0.01	0.04 0.05	Ω
NC, NO OFF leakage current	I _{NC(OFF)} , I _{NO(OFF)} V _{NC} or V _{NO} = 1 V, V _{COM} = 3 V, or V _{NC} or V _{NO} = 3 V, V _{COM} = 1 V,	25°C Full	3.6 V	–10		10 50	nA	
NC, NO ON leakage current	I _{NC(ON)} , I _{NO(ON)} V _{NC} or V _{NO} = 1 V, V _{COM} = Open, or V _{NC} or V _{NO} = 3 V, V _{COM} = Open,	25°C Full	3.6 V	–10		10 100	nA	
COM ON leakage current	I _{COM(ON)} V _{NC} or V _{NO} = Open, V _{COM} = 1 V, or V _{NC} or V _{NO} = Open, V _{COM} = 3 V,	25°C Full	3.6 V	–10		10 100	nA	
DIGITAL CONTROL INPUTS (IN1, IN2)⁽²⁾								
Input logic high	V _{IH}	Full		1.4			V	
Input logic low	V _{IL}	Full				0.5	V	
Input leakage current	I _{IH} , I _{IL} V _I = 3.6 V or 0	25°C Full	3.6 V	–40	5	40 50	nA	

6.5 Electrical Characteristics for 3-V Supply (continued)

 $V_{CC} = 2.7\text{ V to }3.6\text{ V}$, $T_A = -40^\circ\text{C to }85^\circ\text{C}$ (unless otherwise noted) ⁽¹⁾

PARAMETER	TEST CONDITIONS	T_A	V_{CC}	MIN	TYP	MAX	UNIT
DYNAMIC							
Charge injection	Q_C $V_{GEN} = 0$, $R_{GEN} = 0$, $C_L = 1\text{ nF}$, See Figure 7-10	25°C	3 V		9		pC
NC, NO OFF capacitance	$C_{NC(OFF)}$, $C_{NO(OFF)}$ V_{NC} or $V_{NO} = V_{CC}$ or GND, Switch OFF, See Figure 7-4	25°C	3 V		90		pF
NC, NO ON capacitance	$C_{NC(ON)}$, $C_{NO(ON)}$ V_{NC} or $V_{NO} = V_{CC}$ or GND, Switch ON, See Figure 7-4	25°C	3 V		224		pF
COM ON capacitance	$C_{COM(ON)}$ $V_{COM} = V_{CC}$ or GND, Switch ON, See Figure 7-4	25°C	3 V		250		pF
Digital input capacitance	C_I $V_{IN} = V_{CC}$ or GND, See Figure 7-4	25°C	3 V		2		pF
Bandwidth	BW $R_L = 50\ \Omega$, Switch ON, See Figure 7-7	25°C	3 V		23		MHz
OFF isolation	O_{ISO} $R_L = 50\ \Omega$, $f = 1\text{ MHz}$, See Figure 7-8	25°C	3 V		-72		dB
Crosstalk	X_{TALK} $R_L = 50\ \Omega$, $f = 1\text{ MHz}$, See Figure 7-9	25°C	3 V		-96		dB
Total harmonic distortion	THD $R_L = 600\ \Omega$, $C_L = 50\text{ pF}$, $f = 20\text{ Hz to }20\text{ kHz}$, See Figure 7-11	25°C	3 V		0.003%		
SUPPLY							
Positive supply current	I_{CC} $V_{IN} = V_{CC}$ or GND	25°C	3.6 V		15	100	nA
		Full			1		μA

- (1) The algebraic convention, whereby the most negative value is a minimum and the most positive value is a maximum
(2) All unused digital inputs of the device must be held at V_{CC} or GND to ensure proper device operation. Refer to the TI application report, [Implications of Slow or Floating CMOS Inputs](#).

6.6 Electrical Characteristics for 2.5-V Supply

 $V_{CC} = 2.3\text{ V to }2.7\text{ V}$, $T_A = -40^\circ\text{C to }85^\circ\text{C}$ (unless otherwise noted) ⁽¹⁾

PARAMETER	TEST CONDITIONS	T_A	V_{CC}	MIN	TYP	MAX	UNIT
ANALOG SWITCH							
Analog signal range	V_{COM} , V_{NO} , V_{NC}			0		V_{CC}	V
Peak ON resistance	r_{peak} $0 \leq (V_{NO} \text{ or } V_{NC}) \leq V_{CC}$, $I_{COM} = -8\text{ mA}$, Switch ON, See Figure 7-1	25°C	2.3 V			0.35	Ω
		Full				0.45	
ON-state resistance	r_{on} V_{NO} or $V_{NC} = 1.8\text{ V}$, $I_{COM} = -8\text{ mA}$, Switch ON, See Figure 7-1	25°C	2.3 V				Ω
		Full				0.4	
ON-state resistance match between channels	Δr_{on} V_{NO} or $V_{NC} = 1.8\text{ V}, 0.8\text{ V}$, $I_{COM} = -8\text{ mA}$, Switch ON, See Figure 7-1	25°C	2.3 V		0.01	0.05	Ω
		Full			0.05	0.05	
ON-state resistance flatness	$r_{on(Flat)}$ $0 \leq (V_{NO} \text{ or } V_{NC}) \leq V_{CC}$, $I_{COM} = -8\text{ mA}$, Switch ON, See Figure 7-1	25°C	2.3 V			0.05	Ω
		Full				0.03	
NC, NO OFF leakage current	$I_{NC(OFF)}$, $I_{NO(OFF)}$ V_{NC} or $V_{NO} = 0.5\text{ V}, V_{COM} = 2.2\text{ V}$, or V_{NC} or $V_{NO} = 2.2\text{ V}, V_{COM} = 0.5\text{ V}$, Switch OFF, See Figure 7-2	25°C	2.7 V	-10		10	nA
		Full			-50		

6.6 Electrical Characteristics for 2.5-V Supply (continued)

 $V_{CC} = 2.3 \text{ V to } 2.7 \text{ V}$, $T_A = -40^\circ\text{C to } 85^\circ\text{C}$ (unless otherwise noted) ⁽¹⁾

PARAMETER		TEST CONDITIONS		T_A	V_{CC}	MIN	TYP	MAX	UNIT
NC, NO ON leakage current	$I_{NC(ON)}$, $I_{NO(ON)}$	V_{NC} or $V_{NO} = 0.5 \text{ V}$, $V_{COM} = \text{Open}$, or V_{NC} or $V_{NO} = 2.2 \text{ V}$, $V_{COM} = \text{Open}$,	Switch ON, See Figure 7-3	25°C	2.7 V	-10		10	nA
				Full		-100		100	
ANALOG SWITCH (continued)									
COM ON leakage current	$I_{COM(ON)}$	V_{NC} or $V_{NO} = \text{Open}$, $V_{COM} = 0.5 \text{ V}$, or V_{NC} or $V_{NO} = \text{Open}$, $V_{COM} = 2.2 \text{ V}$,	Switch ON, See Figure 7-3	25°C	2.7 V	-10		10	nA
				Full		-100		100	
DIGITAL CONTROL INPUTS (IN1, IN2)⁽²⁾									
Input logic high	V_{IH}			Full		1.25			V
Input logic low	V_{IL}			Full				0.5	V
Input leakage current	I_{IH} , I_{IL}	$V_I = 2.7 \text{ V}$ or 0		25°C	2.7 V	-40	5	40	nA
				Full		-50		50	
DYNAMIC									
Charge injection	Q_C	$V_{GEN} = 0$, $R_{GEN} = 0$,	$C_L = 1 \text{ nF}$, See Figure 7-10	25°C	2.5 V		8		pC
NC, NO OFF capacitance	$C_{NC(OFF)}$, $C_{NO(OFF)}$	V_{NC} or $V_{NO} = V_{CC}$ or GND, Switch OFF,	See Figure 7-4	25°C	2.5 V		90		pF
NC, NO ON capacitance	$C_{NC(ON)}$, $C_{NO(ON)}$	V_{NC} or $V_{NO} = V_{CC}$ or GND, Switch ON,	See Figure 7-4	25°C	2.5 V		250		pF
COM ON capacitance	$C_{COM(ON)}$	$V_{COM} = V_{CC}$ or GND, Switch ON,	See Figure 7-4	25°C	2.5 V		250		pF
Digital input capacitance	C_I	$V_I = V_{CC}$ or GND,	See Figure 7-4	25°C	2.5 V		2		pF
Bandwidth	BW	$R_L = 50 \Omega$, Switch ON,	See Figure 7-7	25°C	2.5 V		23		MHz
OFF isolation	O_{ISO}	$R_L = 50 \Omega$, $f = 1 \text{ MHz}$,	See Figure 7-8	25°C	2.5 V		-72		dB
Crosstalk	X_{TALK}	$R_L = 50 \Omega$, $f = 1 \text{ MHz}$,	See Figure 7-9	25°C	2.5 V		-96		dB
Total harmonic distortion	THD	$R_L = 600 \Omega$, $C_L = 50 \text{ pF}$,	$f = 20 \text{ Hz to } 20 \text{ kHz}$, See Figure 7-11	25°C	2.5 V		0.003%		
SUPPLY									
Positive supply current	I_{CC}	$V_I = V_{CC}$ or GND		25°C	2.7 V		10	100	nA
				Full			700		

- (1) The algebraic convention, whereby the most negative value is a minimum and the most positive value is a maximum.
 (2) All unused digital inputs of the device must be held at V_{CC} or GND to ensure proper device operation. Refer to the TI application report, [Implications of Slow or Floating CMOS Inputs](#).

6.7 Electrical Characteristics for 1.8-V Supply

 $V_{CC} = 1.65\text{ V to }1.95\text{ V}$, $T_A = -40^\circ\text{C to }85^\circ\text{C}$ (unless otherwise noted) ⁽¹⁾

PARAMETER	TEST CONDITIONS	T_A	V_{CC}	MIN	TYP	MAX	UNIT
ANALOG SWITCH							
Analog signal range	V_{COM}, V_{NO}, V_{NC}			0		V_{CC}	V
Peak ON resistance	r_{peak} $0 \leq (V_{NO} \text{ or } V_{NC}) \leq V_{CC}$, $I_{COM} = -2\text{ mA}$,	Switch ON, See Figure 7-1	25°C Full	1.65 V	0.4	0.7 0.8	Ω
ON-state resistance	r_{on} $V_{NO} \text{ or } V_{NC} = 1.5\text{ V}$, $I_{COM} = -2\text{ mA}$,	Switch ON, See Figure 7-1	25°C Full	1.65 V	0.3	0.45 0.5	Ω
ANALOG SWITCH (continued)							
ON-state resistance match between channels	Δr_{on} $V_{NO} \text{ or } V_{NC} = 0.6\text{ V}, 1.5\text{ V}$, $I_{COM} = -2\text{ mA}$,	Switch ON, See Figure 7-1	25°C Full	1.65 V	0.02	0.04 0.05	Ω
ON-state resistance flatness	$r_{on(Flat)}$ $0 \leq (V_{NO} \text{ or } V_{NC}) \leq V_{CC}$, $I_{COM} = -2\text{ mA}$, $V_{NO} \text{ or } V_{NC} = 0.6\text{ V}, 1.5\text{ V}$, $I_{COM} = -8\text{ mA}$,	Switch ON, See Figure 7-1 Switch ON, See Figure 7-1	25°C 25°C Full	1.65 V	0.13	0.08 0.15 0.2	Ω
NC, NO OFF leakage current	$I_{NC(OFF)}, I_{NO(OFF)}$ $V_{NC} \text{ or } V_{NO} = 0.3\text{ V}, V_{COM} = 1.65\text{ V}$, or $V_{NC} \text{ or } V_{NO} = 1.65\text{ V}, V_{COM} = 0.3\text{ V}$,	Switch OFF, See Figure 7-2	25°C Full	1.95	-10	10 50	nA
NC, NO ON leakage current	$I_{NC(ON)}, I_{NO(ON)}$ $V_{NC} \text{ or } V_{NO} = 0.3\text{ V}, V_{COM} = \text{Open}$, or $V_{NC} \text{ or } V_{NO} = 1.65\text{ V}, V_{COM} = \text{Open}$,	Switch ON, See Figure 7-3	25°C Full	1.95 V	-10	10 100	nA
COM ON leakage current	$I_{COM(ON)}$ $V_{NC} \text{ or } V_{NO} = \text{Open}, V_{COM} = 0.3\text{ V}$, or $V_{NC} \text{ or } V_{NO} = \text{Open}, V_{COM} = 1.65\text{ V}$,	Switch ON, See Figure 7-3	25°C Full	1.95 V	-10	10 100	nA
DIGITAL CONTROL INPUTS (IN1, IN2)⁽²⁾							
Input logic high	V_{IH}		Full		1		V
Input logic low	V_{IL}		Full			0.4	V
Input leakage current	I_{IH}, I_{IL}	$V_I = 1.95\text{ V or }0$	25°C Full	1.95 V	-40	5 40 50	nA
DYNAMIC							
Charge injection	Q_C	$V_{GEN} = 0$, $R_{GEN} = 0$,	$C_L = 1\text{ nF}$, See Figure 7-10	25°C	1.8 V	5	pC
NC, NO OFF capacitance	$C_{NC(OFF)}, C_{NO(OFF)}$	$V_{NC} \text{ or } V_{NO} = V_{CC} \text{ or } GND$, Switch OFF,	See Figure 7-4	25°C	1.8 V	90	pF
NC, NO ON capacitance	$C_{NC(ON)}, C_{NO(ON)}$	$V_{NC} \text{ or } V_{NO} = V_{CC} \text{ or } GND$, Switch ON,	See Figure 7-4	25°C	1.8 V	250	pF
COM ON capacitance	$C_{COM(ON)}$	$V_{COM} = V_{CC} \text{ or } GND$, Switch ON,	See Figure 7-4	25°C	1.8 V	250	pF
Digital input capacitance	C_{IN}	$V_I = V_{CC} \text{ or } GND$,	See Figure 7-4	25°C	1.8 V	2	pF
Bandwidth	BW	$R_L = 50\ \Omega$, Switch ON,	See Figure 7-7	25°C	1.8 V	23	MHz
OFF isolation	O_{ISO}	$R_L = 50\ \Omega$, $f = 1\text{ MHz}$,	See Figure 7-8	25°C	1.8 V	-73	dB
Crosstalk	X_{TALK}	$R_L = 50\ \Omega$, $f = 1\text{ MHz}$,	See Figure 7-9	25°C	1.8 V	-97	dB

6.7 Electrical Characteristics for 1.8-V Supply (continued)

$V_{CC} = 1.65\text{ V to }1.95\text{ V}$, $T_A = -40^\circ\text{C to }85^\circ\text{C}$ (unless otherwise noted) ⁽¹⁾

PARAMETER	TEST CONDITIONS	T_A	V_{CC}	MIN	TYP	MAX	UNIT
Total harmonic distortion THD	$R_L = 600\ \Omega$, $C_L = 50\ \text{pF}$, $f = 20\ \text{Hz to }20\ \text{kHz}$, See Figure 7-11	25°C	1.8 V	0.005%			
SUPPLY							
Positive supply current I_{CC}	$V_I = V_{CC}$ or GND	25°C	1.95 V	100		50	nA
		Full		700			

- (1) The algebraic convention, whereby the most negative value is a minimum and the most positive value is a maximum
(2) All unused digital inputs of the device must be held at V_{CC} or GND to ensure proper device operation. Refer to the TI application report, [Implications of Slow or Floating CMOS Inputs](#).

6.8 Switching Characteristics for a 3-V Supply

$V_{CC} = 2.7\text{ V to }3.6\text{ V}$, $T_A = -40^\circ\text{C to }85^\circ\text{C}$ (unless otherwise noted) ⁽¹⁾

PARAMETER	TEST CONDITIONS	T_A	V_{CC}	MIN	TYP	MAX	UNIT
Dynamic							
Turnon time t_{ON}	$V_{COM} = V_{CC}$, $R_L = 50\ \Omega$, $C_L = 35\ \text{pF}$, See Figure 7-5	25°C	3.0 V	20		35	ns
		Full	2.7 V to 3.6 V	40			
Turnoff time t_{OFF}	$V_{COM} = V_{CC}$, $R_L = 50\ \Omega$, $C_L = 35\ \text{pF}$, See Figure 7-5	25°C	3.0 V	12		25	ns
		Full	2.7 V to 3.6 V	30			
Break-before-make time t_{BBM}	$V_{NC} = V_{NO} = V_{CC}$, $R_L = 50\ \Omega$, $C_L = 35\ \text{pF}$, See Figure 7-6	25°C	3.0 V	1	10	25	ns
		Full	2.7 V to 3.6 V	0.5		30	

- (1) The algebraic convention, whereby the most negative value is a minimum and the most positive value is a maximum.

6.9 Switching Characteristics for a 2.5-V Supply

$V_{CC} = 2.3\text{ V to }2.7\text{ V}$, $T_A = -40^\circ\text{C to }85^\circ\text{C}$ (unless otherwise noted) ⁽¹⁾

PARAMETER	TEST CONDITIONS	T_A	V_{CC}	MIN	TYP	MAX	UNIT
Dynamic							
Turnon time t_{ON}	$V_{COM} = V_{CC}$, $R_L = 50\ \Omega$, $C_L = 35\ \text{pF}$, See Figure 7-5	25°C	2.5 V	23		45	ns
		Full	2.3 V to 2.7 V	50			
Turnoff time t_{OFF}	$V_{COM} = V_{CC}$, $R_L = 50\ \Omega$, $C_L = 35\ \text{pF}$, See Figure 7-5	25°C	2.5 V	17		27	ns
		Full	2.3 V to 2.7 V	30			
Break-before-make time t_{BBM}	$V_{NC} = V_{NO} = V_{CC}$, $R_L = 50\ \Omega$, $C_L = 35\ \text{pF}$, See Figure 7-6	25°C	2.5 V	2	14	30	ns
		Full	2.3 V to 2.7 V	1		35	

- (1) The algebraic convention, whereby the most negative value is a minimum and the most positive value is a maximum.

6.10 Switching Characteristics for a 1.8-V Supply

$V_{CC} = 1.65\text{ V to }1.95\text{ V}$, $T_A = -40^\circ\text{C to }85^\circ\text{C}$ (unless otherwise noted) ⁽¹⁾

PARAMETER	TEST CONDITIONS	T_A	V_{CC}	MIN	TYP	MAX	UNIT		
Dynamic									
Turnon time	t_{ON}	$V_{COM} = V_{CC}$, $R_L = 50\ \Omega$	$C_L = 35\text{ pF}$, See Figure 7-5	25°C	1.8 V	53	75	ns	
				Full	1.65 V to 1.96 V		80		
Turnoff time	t_{OFF}	$V_{COM} = V_{CC}$, $R_L = 50\ \Omega$	$C_L = 35\text{ pF}$, See Figure 7-5	25°C	1.8 V	24	35	ns	
				Full	1.65 V to 1.96 V		40		
Break-before-make time	t_{BBM}	$V_{NC} = V_{NO} = V_{CC}$, $R_L = 50\ \Omega$	$C_L = 35\text{ pF}$, See Figure 7-6	25°C	1.8 V	2	30	40	ns
				Full	1.65 V to 1.96 V	1		50	

(1) The algebraic convention, whereby the most negative value is a minimum and the most positive value is a maximum.

6.11 Typical Characteristics

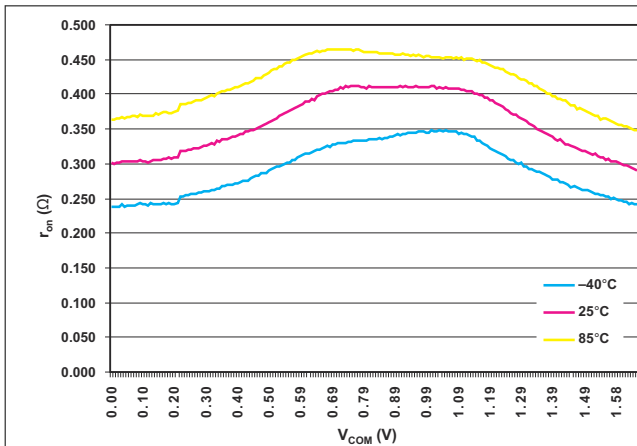

Figure 6-1. r_{on} vs V_{COM} ($V_{CC} = 1.65$ V)

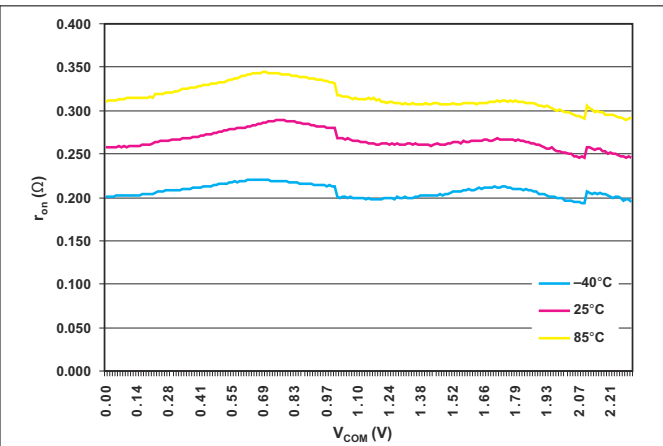

Figure 6-2. r_{on} vs V_{COM} ($V_{CC} = 2.3$ V)

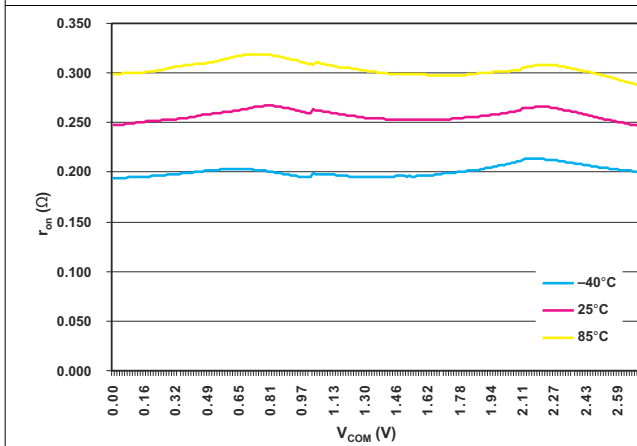

Figure 6-3. r_{on} vs V_{COM} ($V_{CC} = 2.7$ V)

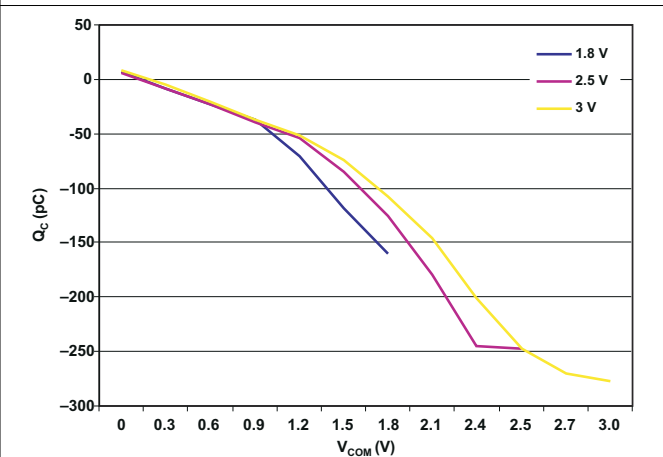

Figure 6-4. Charge Injection (Q_C) vs V_{COM} ($T_A = 25^\circ\text{C}$)

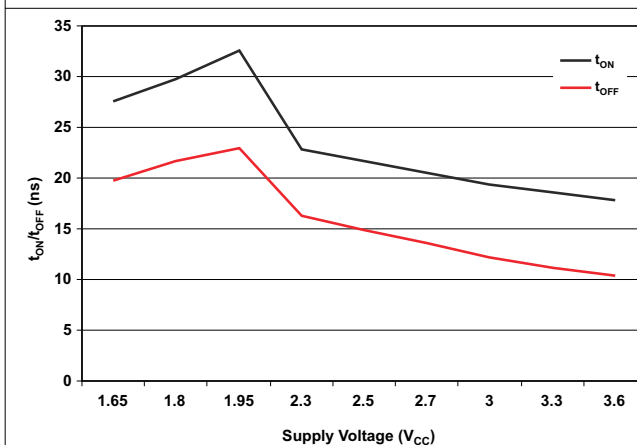

Figure 6-5. t_{ON} and t_{OFF} vs Supply Voltage ($T_A = 25^\circ\text{C}$)

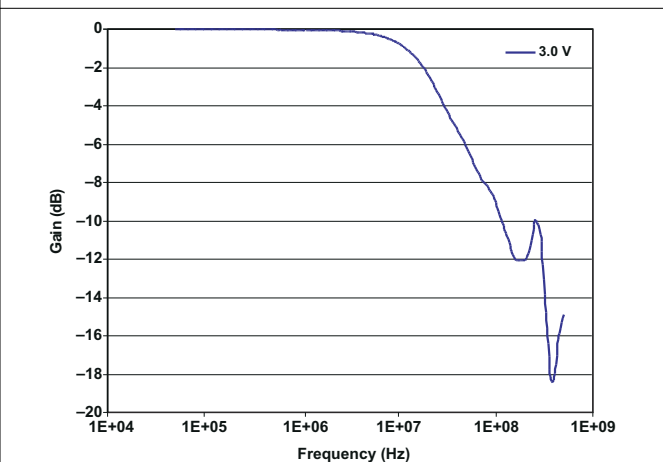
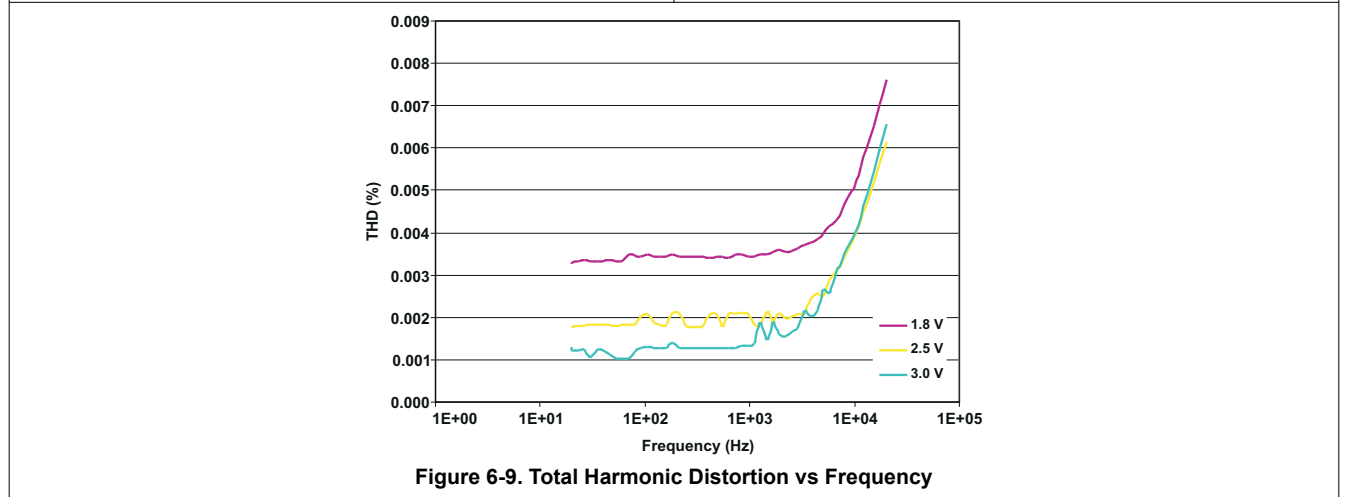
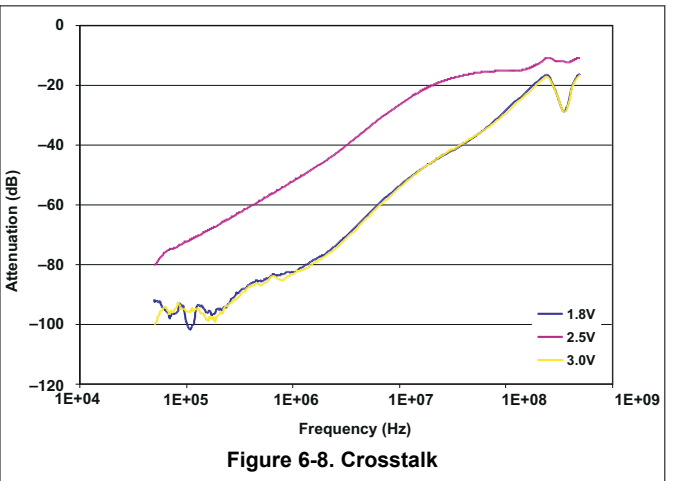
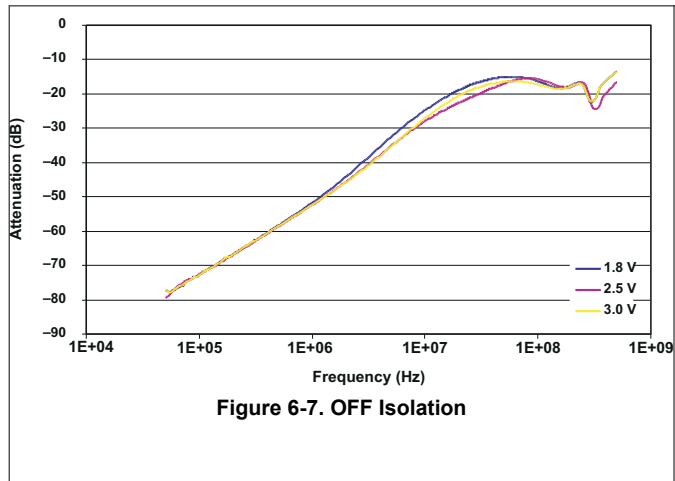

Figure 6-6. Bandwidth

6.11 Typical Characteristics (continued)



7 Parameter Measurement Information

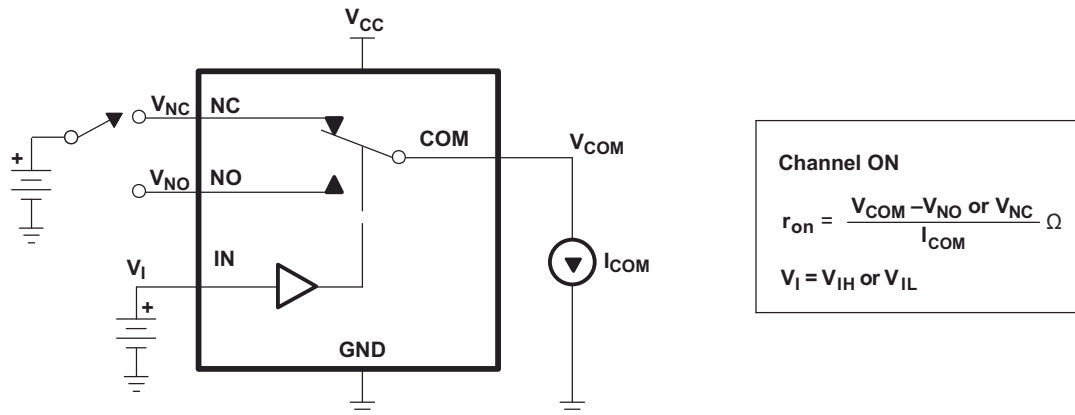

Figure 7-1. ON-State Resistance

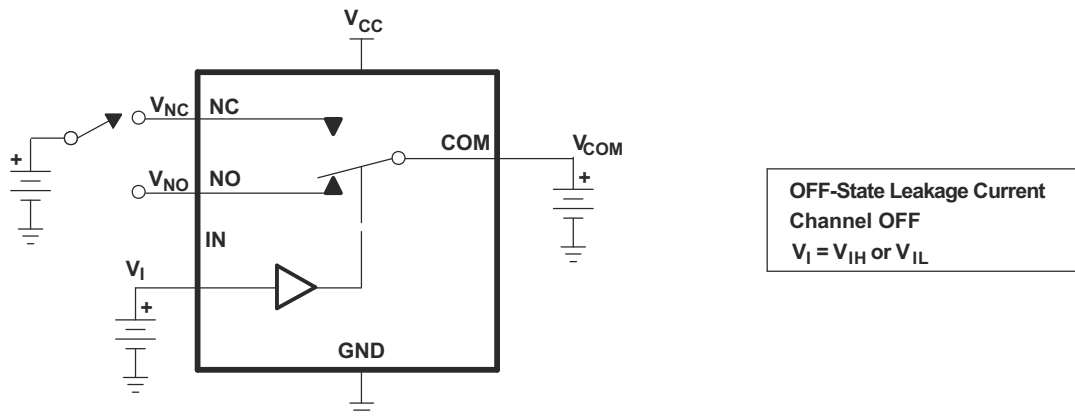

Figure 7-2. OFF-State Leakage Current ($I_{NC(OFF)}$, $I_{NC(PWROFF)}$, $I_{NO(OFF)}$, $I_{NO(PWROFF)}$, $I_{COM(OFF)}$, $I_{COM(PWROFF)}$)

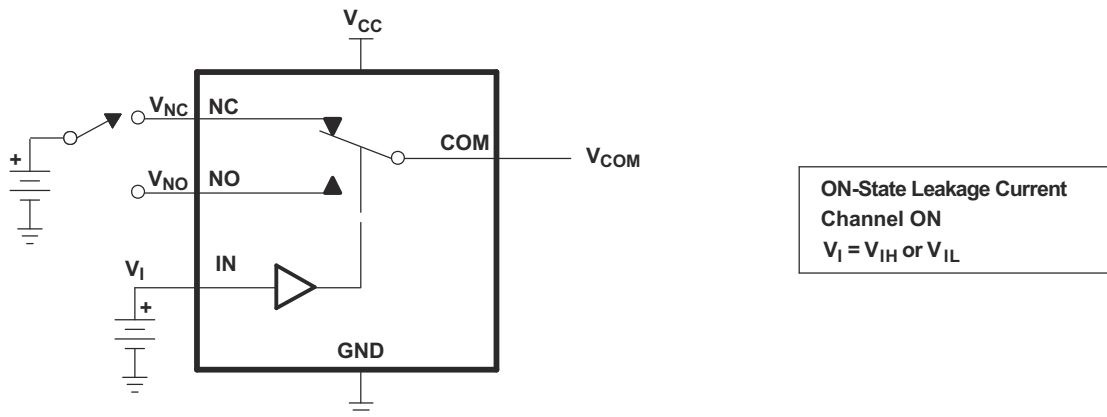

Figure 7-3. ON-State Leakage Current ($I_{COM(ON)}$, $I_{NC(ON)}$, $I_{NO(ON)}$)

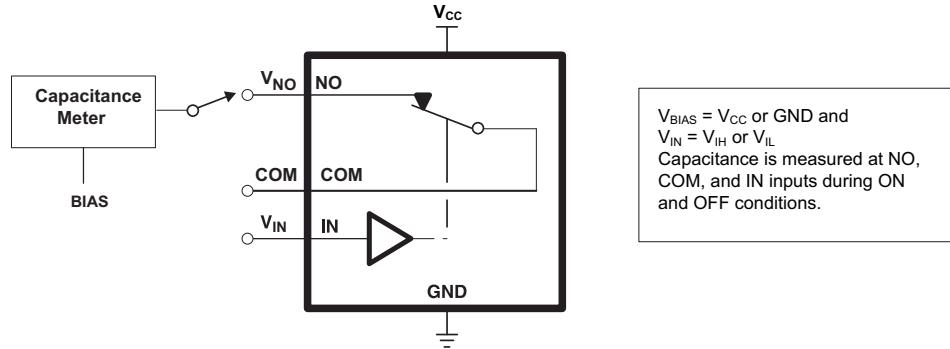
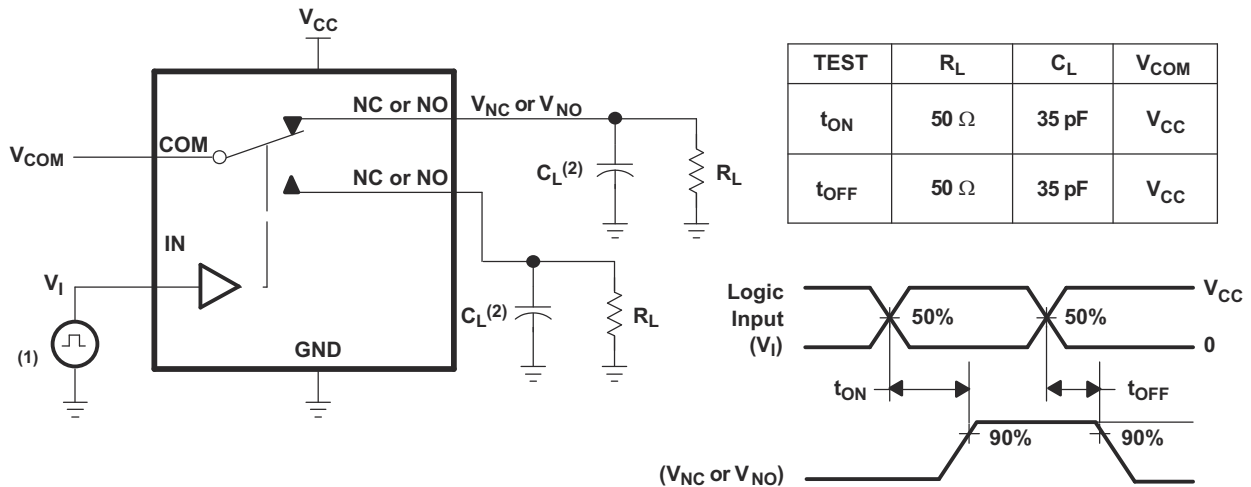
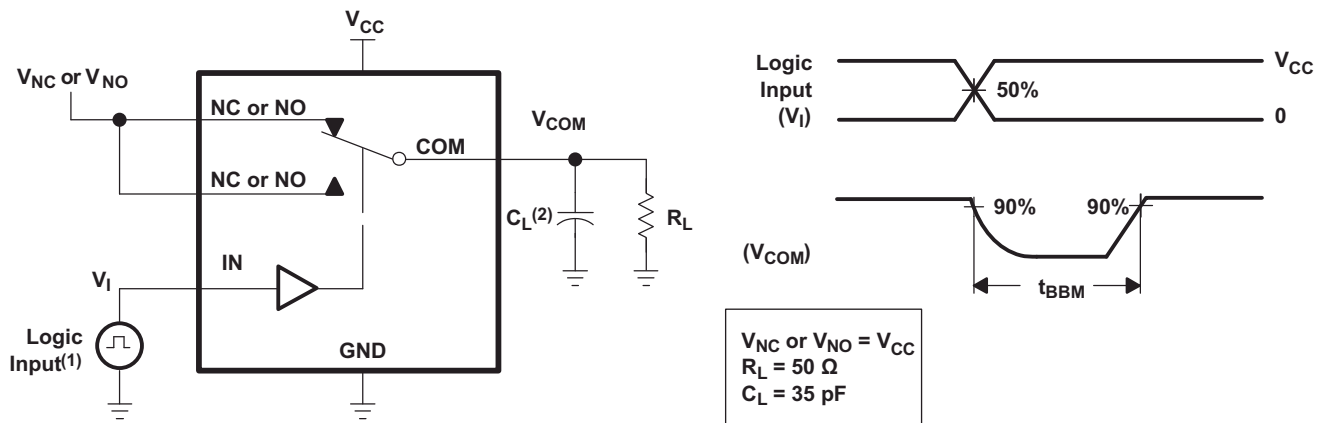

Figure 7-4. Capacitance C_I , $C_{NC(OFF)}$, $C_{NO(OFF)}$, $C_{NC(ON)}$, $C_{NO(ON)}$



- A. All input pulses are supplied by generators having the following characteristics: $PRR \leq 10\ MHz$, $Z_O = 50\ \Omega$, $t_r < 5\ ns$, $t_f < 5\ ns$.
- B. C_L includes probe and jig capacitance.

Figure 7-5. Turn-On (t_{ON}) and Turn-Off Time (t_{OFF})



- A. All input pulses are supplied by generators having the following characteristics: $PRR \leq 10\ MHz$, $Z_O = 50\ \Omega$, $t_r < 5\ ns$, $t_f < 5\ ns$.
- B. C_L includes probe and jig capacitance.

Figure 7-6. Break-Before-Make Time (t_{BBM})

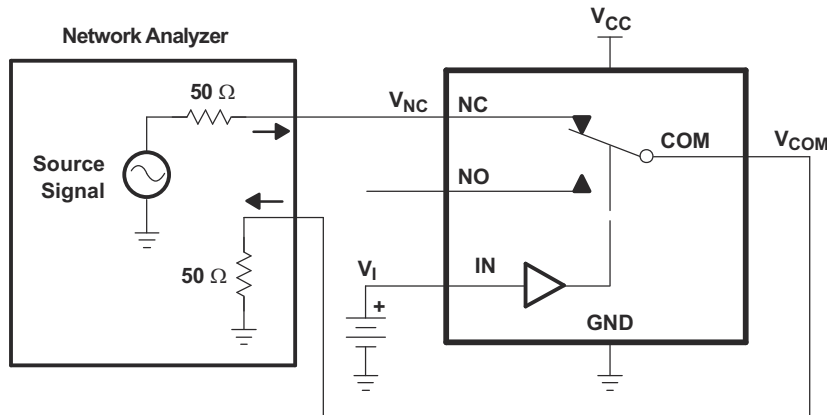

Figure 7-7. Bandwidth (BW)

Channel ON: NC to COM
 $V_I = V_{CC}$ or GND

Network Analyzer Setup
 Source Power = 0 dBm
 (632-mV P-P at 50- Ω load)
 DC Bias = 350 mV

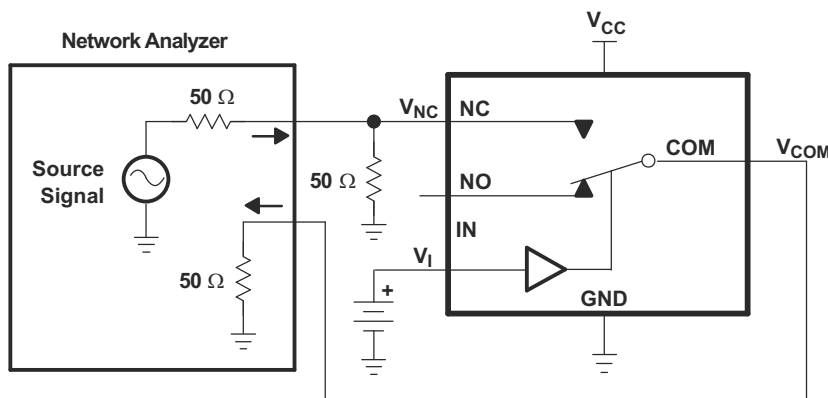

Figure 7-8. OFF Isolation (O_{ISO})

Channel OFF: NC to COM
 $V_I = V_{CC}$ or GND

Network Analyzer Setup
 Source Power = 0 dBm
 (632-mV P-P at 50- Ω load)
 DC Bias = 350 mV

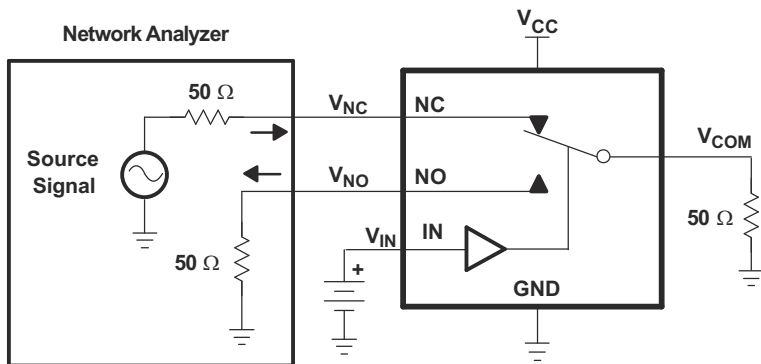
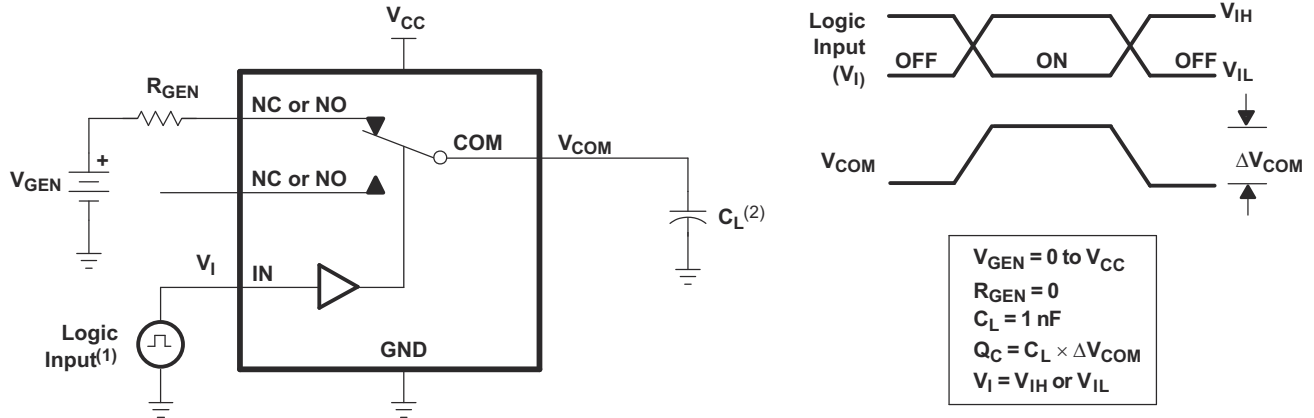

Figure 7-9. Crosstalk (X_{TALK})

Channel ON: NC to COM
 Channel OFF: NO to COM
 $V_{IN} = V_{CC}$ or GND

Network Analyzer Setup
 Source Power = 0 dBm
 (632-mV P-P at 50- Ω load)
 DC Bias = 350 mV



- A. All input pulses are supplied by generators having the following characteristics: $PRR \leq 10 \text{ MHz}$, $Z_O = 50 \Omega$, $t_r < 5 \text{ ns}$, $t_f < 5 \text{ ns}$.
- B. C_L includes probe and jig capacitance.

Figure 7-10. Charge Injection (Q_C)

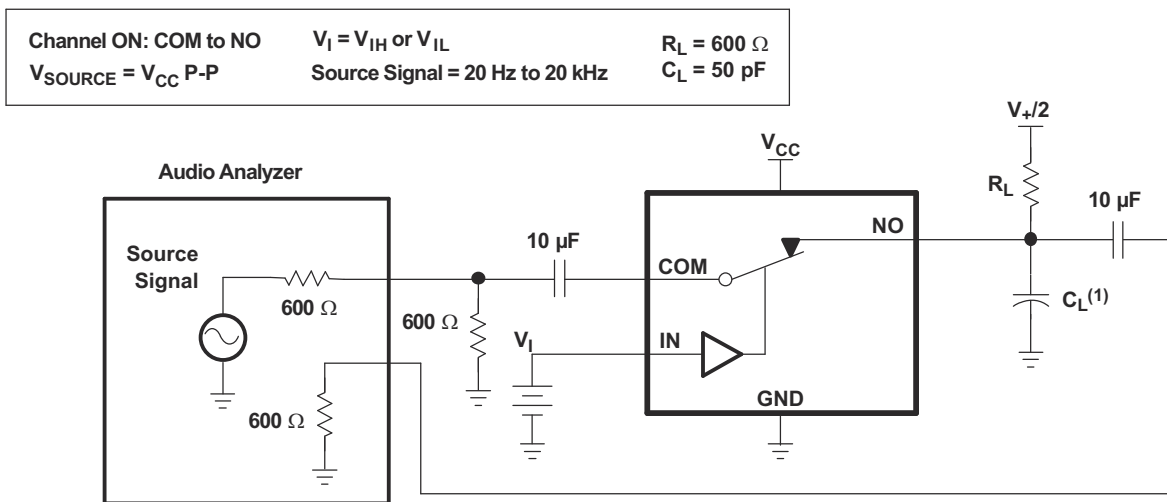

- A. C_L includes probe and jig capacitance.

Figure 7-11. Total Harmonic Distortion (THD)

8 Detailed Description

8.1 Overview

The TS3A24159 is a 2-channel single-pole double-throw (SPDT) bidirectional analog switch that is designed to operate from 1.65 V to 3.6 V. It offers low ON-state resistance and excellent ON-state resistance matching with the break-before-make feature, to prevent signal distortion during the transferring of a signal from one channel to another. The device has excellent total harmonic distortion (THD) performance, low ON-state resistance, and consumes very low power. These are some of the features that make this device suitable for a variety of markets and many different applications.

8.2 Functional Block Diagram

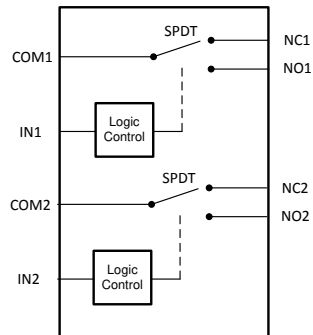

8.3 Feature Description

The TS3A24159 device is bidirectional with two single-pole, double-throw switches. Each of the two switches are controlled independently by two digital signals.

8.4 Device Functional Modes

Table 8-1. Function Table

IN	NC TO COM, COM TO NC	NO TO COM, COM TO NO
L	ON	OFF
H	OFF	ON

9 Application and Implementation

Note

Information in the following applications sections is not part of the TI component specification, and TI does not warrant its accuracy or completeness. TI's customers are responsible for determining suitability of components for their purposes, as well as validating and testing their design implementation to confirm system functionality.

9.1 Application Information

The switch of the TS3A24159 device is bidirectional. Hence, NO, NC, and COM pins can be used as both inputs or outputs.

9.2 Typical Application

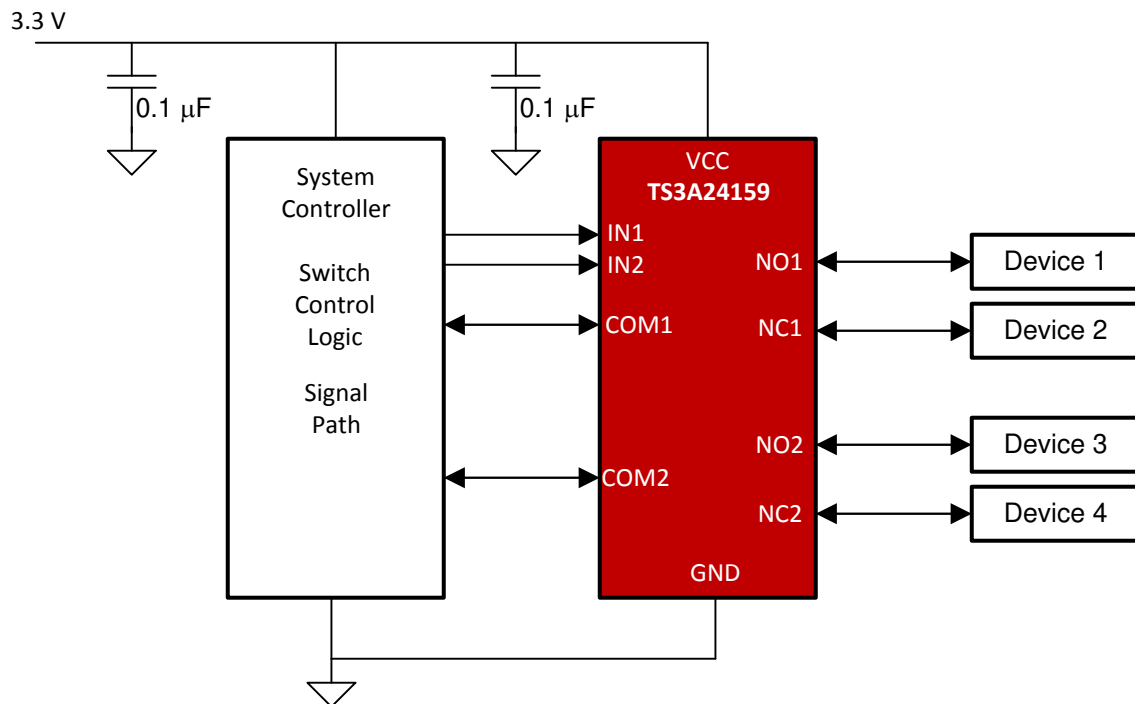

9.2.1 Design Requirements

Ensure that all of the signals passing through the switch are within the specified ranges to ensure proper performance.

Table 9-1. Design Parameters

		MIN	MAX	UNIT
V_{CC}	Supply Voltage	1.65	3.6	V
V_{NC} V_{NO} V_{COM}	Signal Voltage	0	V_{CC}	V
V_{IN}	Digital Input Voltage	0	V_{CC}	V

9.2.2 Detailed Design Procedure

The TS3A24159 device can be properly operated without any external components. However, it is recommended to connect the unused pins to ground through a 50- Ω resistor to prevent signal reflections back into the device. It is also recommended that the digital control pins (IN1 and IN2) be pulled up to V_{CC} or down to GND to avoid undesired switch positions that could result from the floating pin.

Select the appropriate supply voltage to cover the entire voltage swing of the signal passing through the switch because the TS3A24159 input/output signal swing through NO and COM are dependant of the supply voltage V_{CC} .

9.2.3 Application Curve

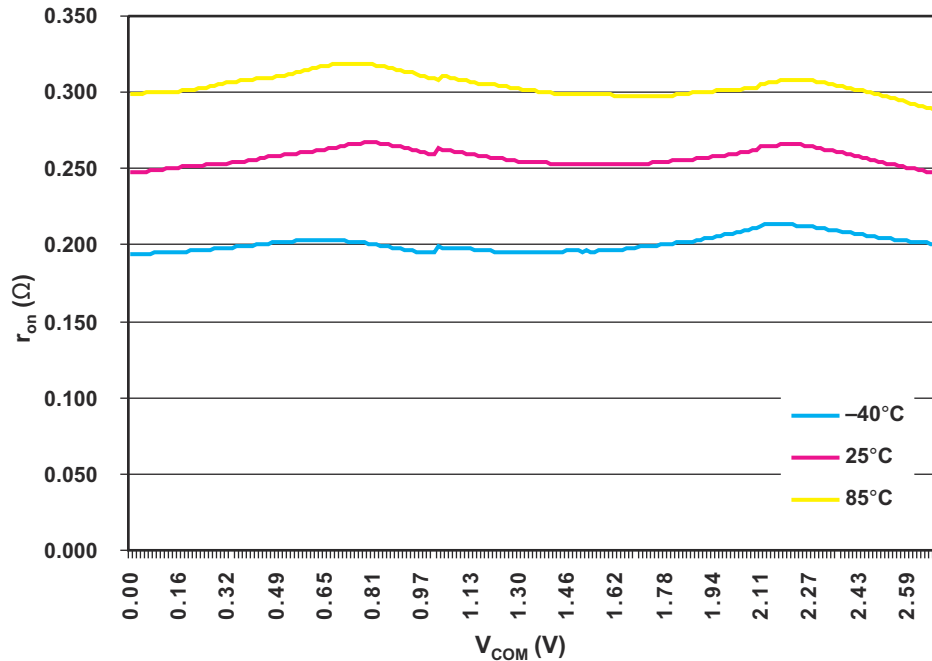

Figure 9-1. r_{ON} vs V_{COM}

10 Power Supply Recommendations

- Proper power-supply sequencing is recommended for all CMOS devices.
- Do not exceed the absolute maximum ratings, because stresses beyond the listed ratings can cause permanent damage to the device.
- Always sequence V_{CC} on first, followed by NO or COM.
- Although it is not required, power-supply bypassing improves noise margin and prevents switching noise propagation from the V_{CC} supply to other components.
- A 0.1- μ F capacitor, connected from V_{CC} to GND, is adequate for most applications.

11 Layout

11.1 Layout Guidelines

To ensure reliability of the device, following common printed-circuit board layout guidelines is recommended. Bypass capacitors must be used on power supplies. Short trace lengths should be used to avoid excessive loading.

11.2 Layout Example

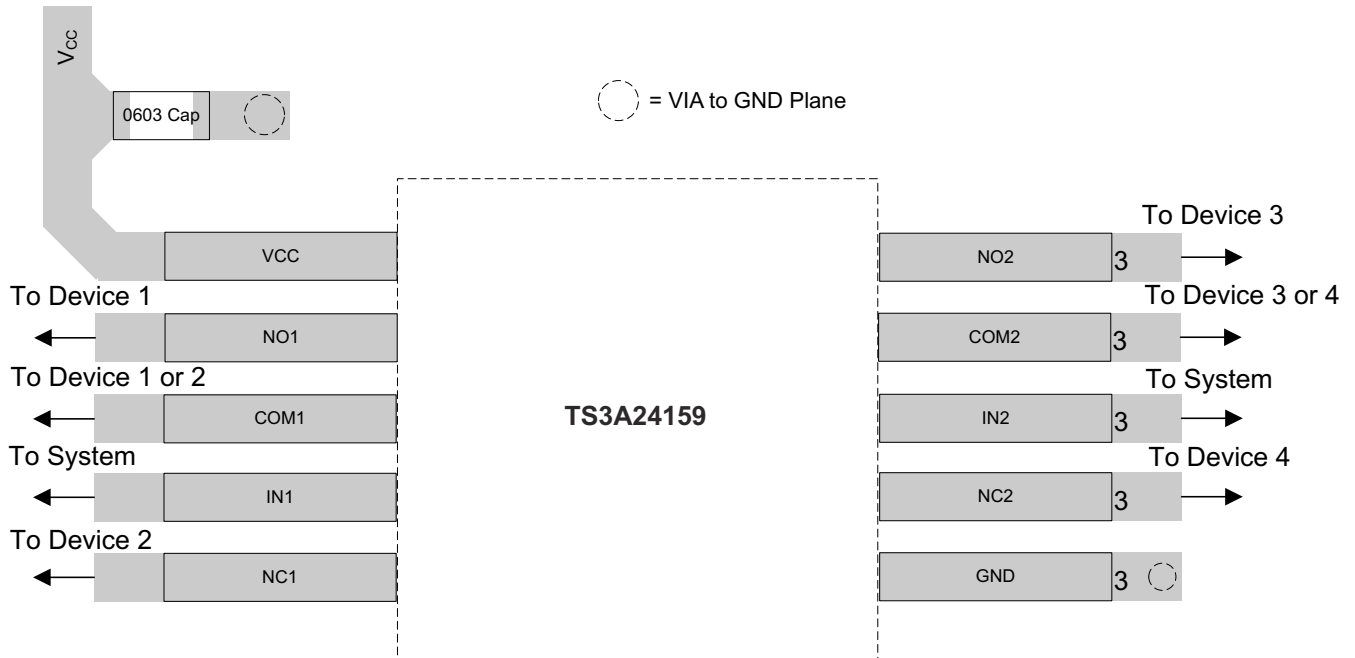

Figure 11-1. Layout Example

12 Device and Documentation Support

12.1 Documentation Support

12.1.1 Related Documentation

For related documentation see the following:

- Texas Instruments, [Implications of Slow or Floating CMOS Inputs application note](#)

12.2 Receiving Notification of Documentation Updates

To receive notification of documentation updates, navigate to the device product folder on [ti.com](#). Click on [Subscribe to updates](#) to register and receive a weekly digest of any product information that has changed. For change details, review the revision history included in any revised document.

12.3 Support Resources

[TI E2E™ support forums](#) are an engineer's go-to source for fast, verified answers and design help — straight from the experts. Search existing answers or ask your own question to get the quick design help you need.

Linked content is provided "AS IS" by the respective contributors. They do not constitute TI specifications and do not necessarily reflect TI's views; see TI's [Terms of Use](#).

12.4 Trademarks

TI E2E™ is a trademark of Texas Instruments.

All trademarks are the property of their respective owners.

12.5 Electrostatic Discharge Caution



This integrated circuit can be damaged by ESD. Texas Instruments recommends that all integrated circuits be handled with appropriate precautions. Failure to observe proper handling and installation procedures can cause damage.

ESD damage can range from subtle performance degradation to complete device failure. Precision integrated circuits may be more susceptible to damage because very small parametric changes could cause the device not to meet its published specifications.

12.6 Glossary

[TI Glossary](#) This glossary lists and explains terms, acronyms, and definitions.

13 Mechanical, Packaging, and Orderable Information

The following pages include mechanical, packaging, and orderable information. This information is the most current data available for the designated devices. This data is subject to change without notice and revision of this document. For browser-based versions of this data sheet, refer to the left-hand navigation.

PACKAGING INFORMATION

Orderable Device	Status (1)	Package Type	Package Drawing	Pins	Package Qty	Eco Plan (2)	Lead finish/ Ball material (6)	MSL Peak Temp (3)	Op Temp (°C)	Device Marking (4/5)	Samples
TS3A24159DGSR	ACTIVE	VSSOP	DGS	10	2500	RoHS & Green	NIPDAU	Level-1-260C-UNLIM	-40 to 85	(L8Q, L8R)	Samples
TS3A24159DGSRG4	LIFEBUY	VSSOP	DGS	10	2500	RoHS & Green	NIPDAU	Level-1-260C-UNLIM	-40 to 85	(L8Q, L8R)	
TS3A24159DRCR	ACTIVE	VSON	DRC	10	3000	RoHS & Green	NIPDAU	Level-2-260C-1 YEAR	-40 to 85	ZWS	Samples
TS3A24159DRCRG4	LIFEBUY	VSON	DRC	10	3000	RoHS & Green	NIPDAU	Level-2-260C-1 YEAR	-40 to 85	ZWS	
TS3A24159YZPR	ACTIVE	DSBGA	YZP	10	3000	RoHS & Green	SNAGCU	Level-1-260C-UNLIM	-40 to 85	L87	Samples

(1) The marketing status values are defined as follows:

ACTIVE: Product device recommended for new designs.

LIFEBUY: TI has announced that the device will be discontinued, and a lifetime-buy period is in effect.

NRND: Not recommended for new designs. Device is in production to support existing customers, but TI does not recommend using this part in a new design.

PREVIEW: Device has been announced but is not in production. Samples may or may not be available.

OBSELETE: TI has discontinued the production of the device.

(2) **RoHS:** TI defines "RoHS" to mean semiconductor products that are compliant with the current EU RoHS requirements for all 10 RoHS substances, including the requirement that RoHS substance do not exceed 0.1% by weight in homogeneous materials. Where designed to be soldered at high temperatures, "RoHS" products are suitable for use in specified lead-free processes. TI may reference these types of products as "Pb-Free".

RoHS Exempt: TI defines "RoHS Exempt" to mean products that contain lead but are compliant with EU RoHS pursuant to a specific EU RoHS exemption.

Green: TI defines "Green" to mean the content of Chlorine (Cl) and Bromine (Br) based flame retardants meet JS709B low halogen requirements of <=1000ppm threshold. Antimony trioxide based flame retardants must also meet the <=1000ppm threshold requirement.

(3) MSL, Peak Temp. - The Moisture Sensitivity Level rating according to the JEDEC industry standard classifications, and peak solder temperature.

(4) There may be additional marking, which relates to the logo, the lot trace code information, or the environmental category on the device.

(5) Multiple Device Markings will be inside parentheses. Only one Device Marking contained in parentheses and separated by a "~" will appear on a device. If a line is indented then it is a continuation of the previous line and the two combined represent the entire Device Marking for that device.

(6) Lead finish/Ball material - Orderable Devices may have multiple material finish options. Finish options are separated by a vertical ruled line. Lead finish/Ball material values may wrap to two lines if the finish value exceeds the maximum column width.

Important Information and Disclaimer:The information provided on this page represents TI's knowledge and belief as of the date that it is provided. TI bases its knowledge and belief on information provided by third parties, and makes no representation or warranty as to the accuracy of such information. Efforts are underway to better integrate information from third parties. TI has taken and

continues to take reasonable steps to provide representative and accurate information but may not have conducted destructive testing or chemical analysis on incoming materials and chemicals. TI and TI suppliers consider certain information to be proprietary, and thus CAS numbers and other limited information may not be available for release.

In no event shall TI's liability arising out of such information exceed the total purchase price of the TI part(s) at issue in this document sold by TI to Customer on an annual basis.

TAPE AND REEL INFORMATION

QUADRANT ASSIGNMENTS FOR PIN 1 ORIENTATION IN TAPE

*All dimensions are nominal

Device	Package Type	Package Drawing	Pins	SPQ	Reel Diameter (mm)	Reel Width W1 (mm)	A0 (mm)	B0 (mm)	K0 (mm)	P1 (mm)	W (mm)	Pin1 Quadrant
TS3A24159DGSR	VSSOP	DGS	10	2500	330.0	12.4	5.3	3.4	1.4	8.0	12.0	Q1
TS3A24159DRCR	VSON	DRC	10	3000	330.0	12.4	3.3	3.3	1.1	8.0	12.0	Q2
TS3A24159YZPR	DSBGA	YZP	10	3000	178.0	9.2	1.49	1.99	0.63	4.0	8.0	Q2

TAPE AND REEL BOX DIMENSIONS

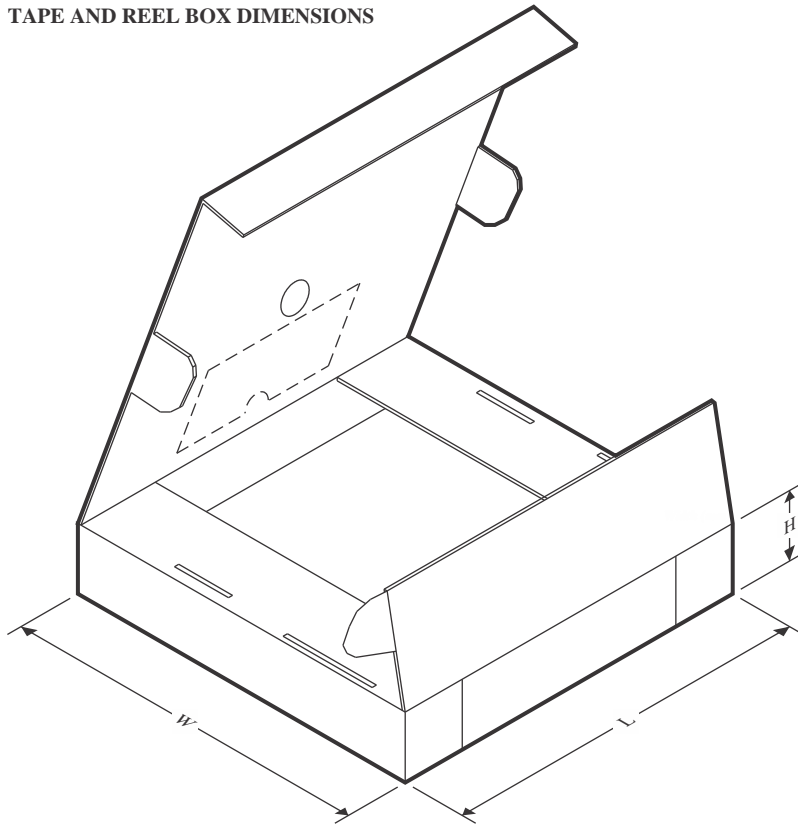

*All dimensions are nominal

Device	Package Type	Package Drawing	Pins	SPQ	Length (mm)	Width (mm)	Height (mm)
TS3A24159DGSR	VSSOP	DGS	10	2500	358.0	335.0	35.0
TS3A24159DRCR	VSON	DRC	10	3000	356.0	356.0	35.0
TS3A24159YZPR	DSBGA	YZP	10	3000	220.0	220.0	35.0

DGS0010A



PACKAGE OUTLINE

VSSOP - 1.1 mm max height

SMALL OUTLINE PACKAGE



4221984/A 05/2015

NOTES:

1. All linear dimensions are in millimeters. Any dimensions in parenthesis are for reference only. Dimensioning and tolerancing per ASME Y14.5M.
2. This drawing is subject to change without notice.
3. This dimension does not include mold flash, protrusions, or gate burrs. Mold flash, protrusions, or gate burrs shall not exceed 0.15 mm per side.
4. This dimension does not include interlead flash. Interlead flash shall not exceed 0.25 mm per side.
5. Reference JEDEC registration MO-187, variation BA.

EXAMPLE BOARD LAYOUT

DGS0010A

VSSOP - 1.1 mm max height

SMALL OUTLINE PACKAGE

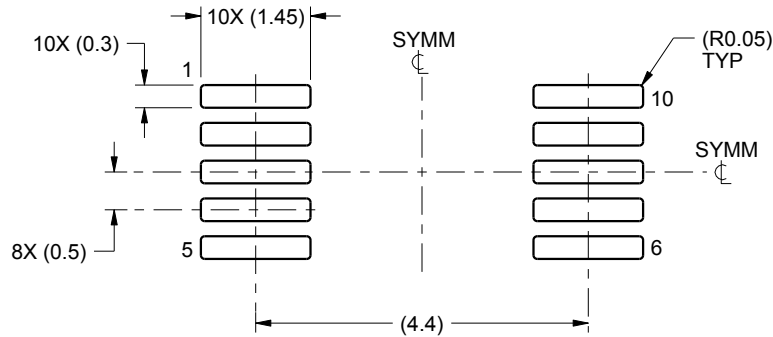

LAND PATTERN EXAMPLE
SCALE:10X

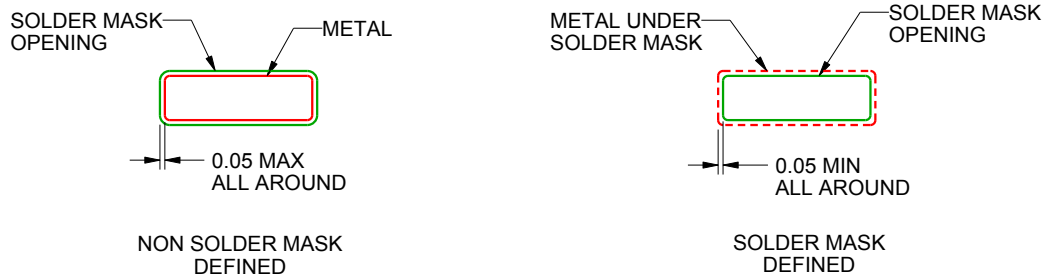

SOLDER MASK DETAILS
NOT TO SCALE

4221984/A 05/2015

NOTES: (continued)

- 6. Publication IPC-7351 may have alternate designs.
- 7. Solder mask tolerances between and around signal pads can vary based on board fabrication site.

EXAMPLE STENCIL DESIGN

DGS0010A

VSSOP - 1.1 mm max height

SMALL OUTLINE PACKAGE



SOLDER PASTE EXAMPLE
BASED ON 0.125 mm THICK STENCIL
SCALE:10X

4221984/A 05/2015

NOTES: (continued)

8. Laser cutting apertures with trapezoidal walls and rounded corners may offer better paste release. IPC-7525 may have alternate design recommendations.
9. Board assembly site may have different recommendations for stencil design.

GENERIC PACKAGE VIEW

DRC 10

VSON - 1 mm max height

3 x 3, 0.5 mm pitch

PLASTIC SMALL OUTLINE - NO LEAD

This image is a representation of the package family, actual package may vary.
Refer to the product data sheet for package details.

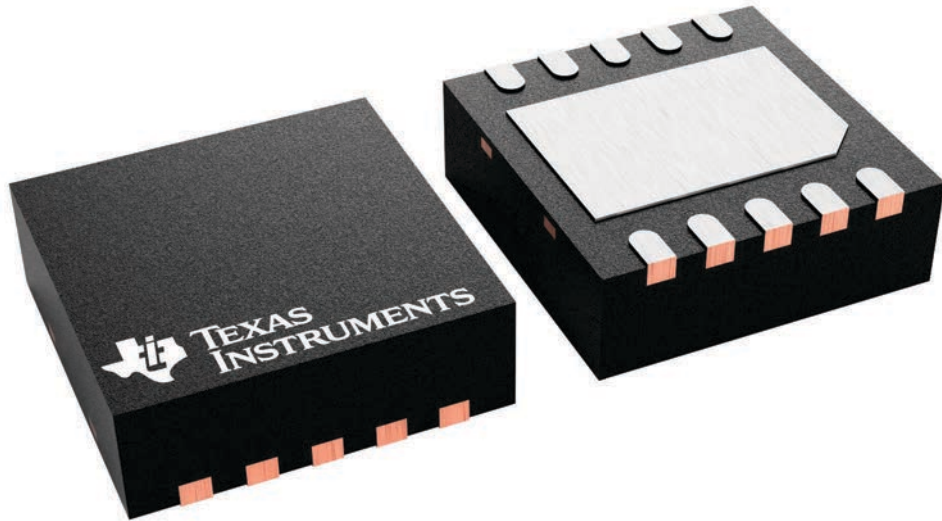

4226193/A

EXAMPLE BOARD LAYOUT

DRC0010J

VSON - 1 mm max height

PLASTIC SMALL OUTLINE - NO LEAD

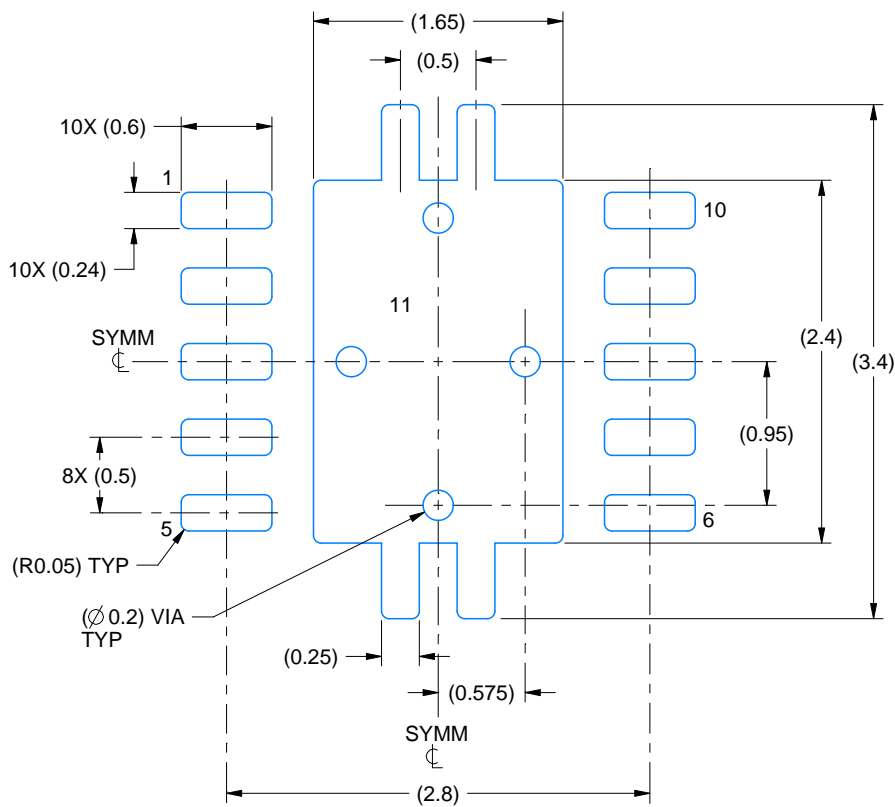

LAND PATTERN EXAMPLE
EXPOSED METAL SHOWN
SCALE:20X

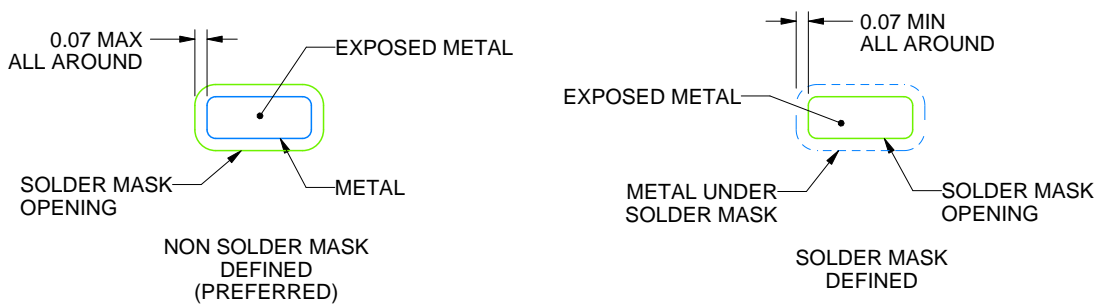

SOLDER MASK DETAILS

4218878/B 07/2018

NOTES: (continued)

4. This package is designed to be soldered to a thermal pad on the board. For more information, see Texas Instruments literature number SLUA271 (www.ti.com/lit/sluea271).
5. Vias are optional depending on application, refer to device data sheet. If any vias are implemented, refer to their locations shown on this view. It is recommended that vias under paste be filled, plugged or tented.

EXAMPLE STENCIL DESIGN

DRC0010J

VSON - 1 mm max height

PLASTIC SMALL OUTLINE - NO LEAD

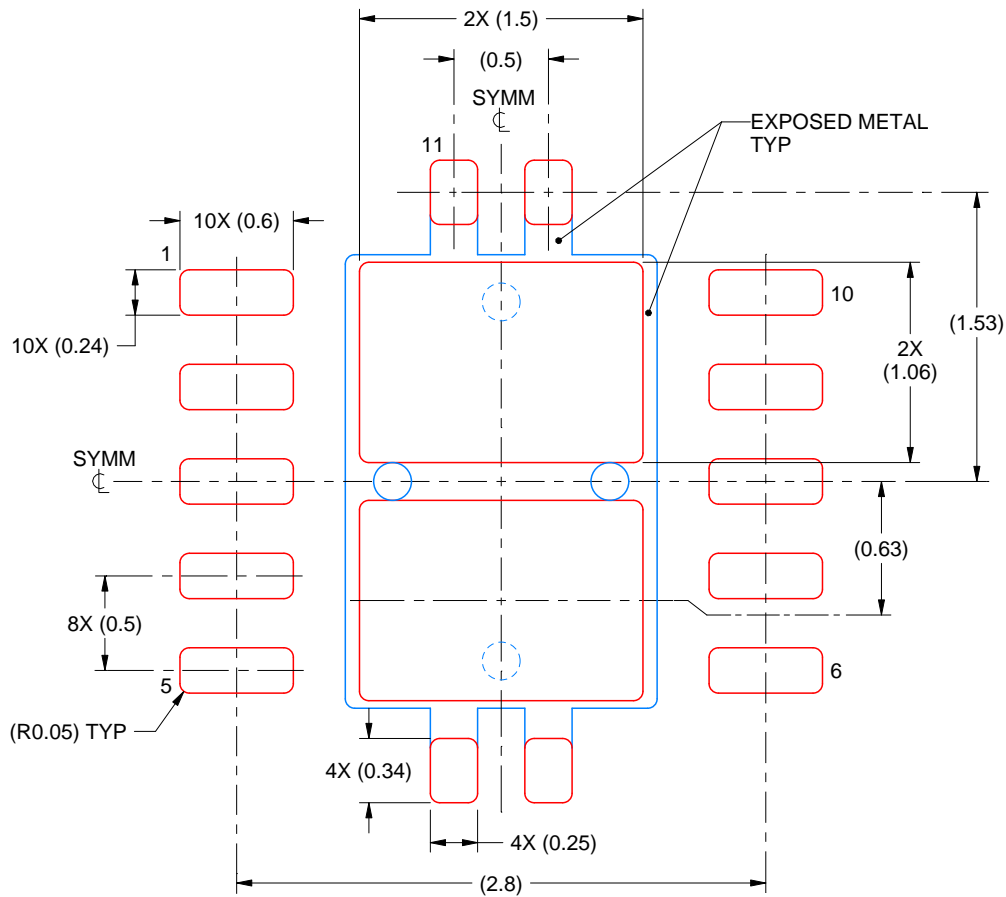

SOLDER PASTE EXAMPLE
BASED ON 0.125 mm THICK STENCIL

EXPOSED PAD 11:
80% PRINTED SOLDER COVERAGE BY AREA
SCALE:25X

4218878/B 07/2018

NOTES: (continued)

6. Laser cutting apertures with trapezoidal walls and rounded corners may offer better paste release. IPC-7525 may have alternate design recommendations.

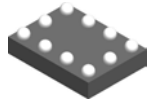

PACKAGE OUTLINE

YZP0010

DSBGA - 0.5 mm max height

DIE SIZE BALL GRID ARRAY

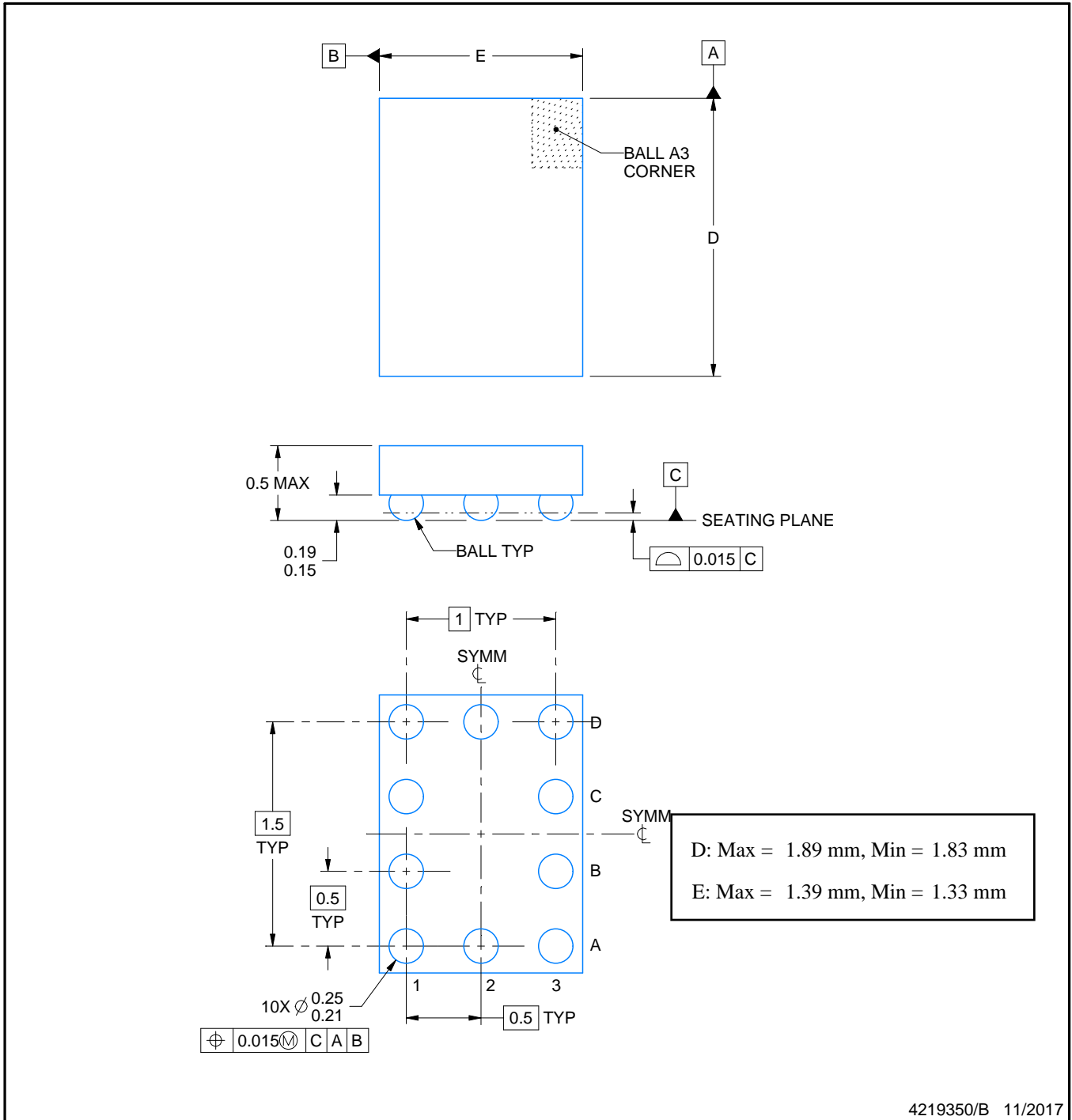

NOTES:

1. All linear dimensions are in millimeters. Any dimensions in parenthesis are for reference only. Dimensioning and tolerancing per ASME Y14.5M.
2. This drawing is subject to change without notice.

EXAMPLE BOARD LAYOUT

YZP0010

DSBGA - 0.5 mm max height

DIE SIZE BALL GRID ARRAY

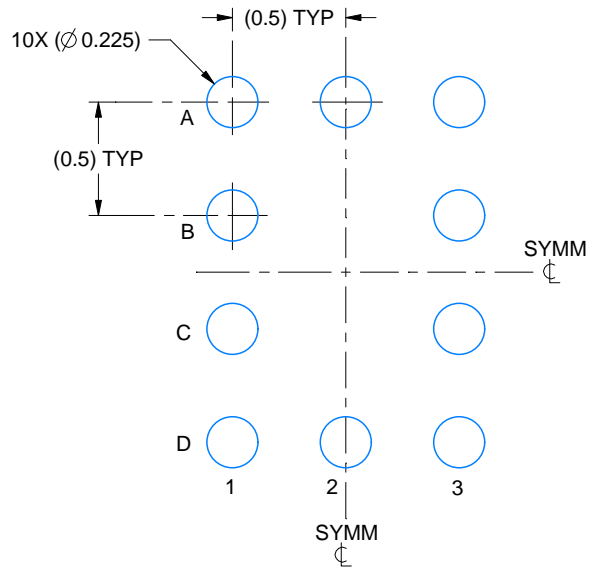

LAND PATTERN EXAMPLE
SCALE:30X

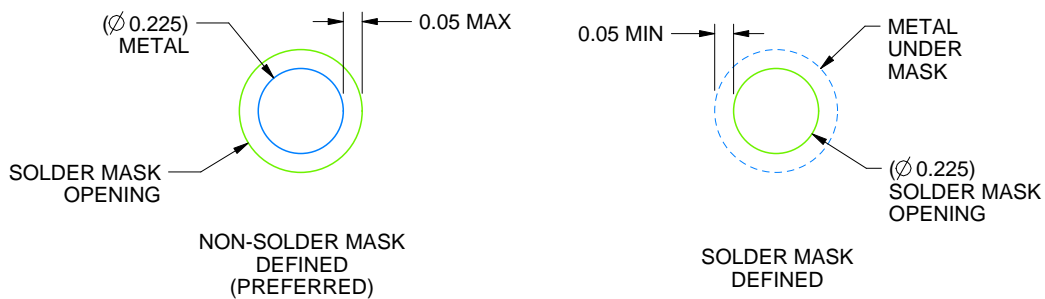

SOLDER MASK DETAILS
NOT TO SCALE

4219350/B 11/2017

NOTES: (continued)

- Final dimensions may vary due to manufacturing tolerance considerations and also routing constraints. For more information, see Texas Instruments literature number SBVA017 (www.ti.com/lit/sbva017).

EXAMPLE STENCIL DESIGN

YZP0010

DSBGA - 0.5 mm max height

DIE SIZE BALL GRID ARRAY

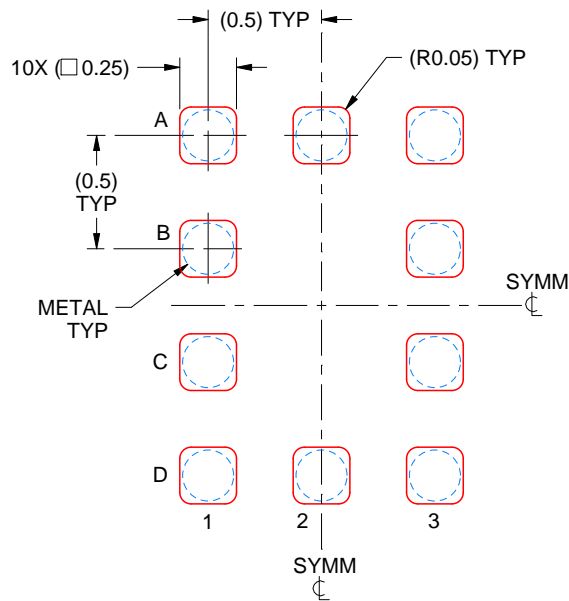

SOLDER PASTE EXAMPLE
BASED ON 0.1 mm THICK STENCIL
SCALE:30X

4219350/B 11/2017

NOTES: (continued)

4. Laser cutting apertures with trapezoidal walls and rounded corners may offer better paste release.

IMPORTANT NOTICE AND DISCLAIMER

TI PROVIDES TECHNICAL AND RELIABILITY DATA (INCLUDING DATA SHEETS), DESIGN RESOURCES (INCLUDING REFERENCE DESIGNS), APPLICATION OR OTHER DESIGN ADVICE, WEB TOOLS, SAFETY INFORMATION, AND OTHER RESOURCES "AS IS" AND WITH ALL FAULTS, AND DISCLAIMS ALL WARRANTIES, EXPRESS AND IMPLIED, INCLUDING WITHOUT LIMITATION ANY IMPLIED WARRANTIES OF MERCHANTABILITY, FITNESS FOR A PARTICULAR PURPOSE OR NON-INFRINGEMENT OF THIRD PARTY INTELLECTUAL PROPERTY RIGHTS.

These resources are intended for skilled developers designing with TI products. You are solely responsible for (1) selecting the appropriate TI products for your application, (2) designing, validating and testing your application, and (3) ensuring your application meets applicable standards, and any other safety, security, regulatory or other requirements.

These resources are subject to change without notice. TI grants you permission to use these resources only for development of an application that uses the TI products described in the resource. Other reproduction and display of these resources is prohibited. No license is granted to any other TI intellectual property right or to any third party intellectual property right. TI disclaims responsibility for, and you will fully indemnify TI and its representatives against, any claims, damages, costs, losses, and liabilities arising out of your use of these resources.

TI's products are provided subject to [TI's Terms of Sale](#) or other applicable terms available either on [ti.com](https://www.ti.com) or provided in conjunction with such TI products. TI's provision of these resources does not expand or otherwise alter TI's applicable warranties or warranty disclaimers for TI products.

TI objects to and rejects any additional or different terms you may have proposed.

Mailing Address: Texas Instruments, Post Office Box 655303, Dallas, Texas 75265
Copyright © 2024, Texas Instruments Incorporated

Looking for pricing, stock, or lifecycle information?

Click below to explore more details on WIN SOURCE:

 [View TS3A24159YZPR on WIN SOURCE](#)

 [Texas Instruments](#) Information

Optimize Your Supply Chain with WIN SOURCE Solutions

-  Global Sourcing Solution
-  Obsolete Management
-  Cost Control Management
-  Shortage Management
-  Alternative Solution
-  Excess Inventory Management