

### Ultra-compact, Ultra-thin Top View FIR-compatible IrDA Module with Built-in Remote Control Transmission Function

## RPM973-H16

#### ●Outline

The RPM973-H16 is a high performance IrDA module that integrates an infrared remote control transmission function and a high-speed (4Mbps) FIR-compatible IrDA module into the world's smallest\* package, resulting in substantial space savings.

#### ●Applications

All types of data communication, including, image data and music transmission data in mobile phones, digital still cameras, and printers

#### ●Features

- 1) Equipped with a remote control function
- 2) Smallest package (7.6x1.7x2.13mm)
- 3) 4Mbps FIR-compatible (faster speeds possible with Ir Simple)

#### ●Absolute maximum ratings (Ta = 25°C)

Parameter	Symbol	Limits	Unit
Supply voltage	Vcc / VLEDA / VIO	6.5 *1	V
Input voltage	Vin(3,4,5pin)	-0.3 to VIO+0.3	V
Operation temperature	Topr	-25 to +85	°C
Storage temperature	Tstg	-40 to +100	°C

\*1) This applies to all pins basis ground pin (7pin).

#### ●Dimensions (Unit : mm)

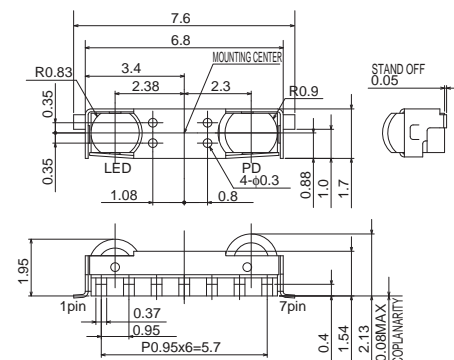

## Photo Link Module

## ●Electrical Optical characteristics (Ta = 25°C)

Recommended operating conditions

Parameter	Symbol	Min.	Typ.	Max.	Unit
Supply voltage	Vcc	2.4	3.0	3.6	V
	VLEDA	2.7	3.0	5.5	V
	VIO	1.7	3.0	Vcc	V

Electrical Optical Characteristics(Unless otherwise noted, Vcc=3V, VLEDVCC=3V, VIO=3V, Ta=25°C)

Parameter	Symbol	Min.	Typ.	Max.	Unit	Conditions
Consumption Current1(SIR/MIR Mode)	Icc1	400	800	1600	μA	PWDOWN=0V, At no input light
Consumption Current2(FIR Mode)	Icc2	400	1000	1600	μA	PWDOWN=0V, At no input light
Consumption Current3(at PWDOWN)	Icc3	–	0.01	0.2	μA	PWDOWN=VIO, At no input light
LED anode current	I <sub>LED</sub>	180	250	300	mA	
Receiver latency time	t <sub>RT</sub>	–	100	200	μs	
Peak wavelength	λ <sub>P</sub>	880		900	nm	
Intensity	I <sub>E</sub>	25	65	–	mW/Sr	–15deg≤θ <sub>L</sub> ≤15deg
Half-angle	θ <sub>L/2</sub>	±15	–	–	deg	
Minimum irradiance in augular1	E <sub>emin1</sub>	–	–	8.1	μW/cm <sup>2</sup>	–15deg≤θ <sub>L</sub> ≤15deg, ≤115.2kbps
Minimum irradiance in augular2	E <sub>emin2</sub>	–	–	20	μW/cm <sup>2</sup>	–15deg≤θ <sub>L</sub> ≤15deg, >115.2kbps
Input half-angle	θ <sub>D/2</sub>	±15	–	–	deg	

### Notes

- No technical content pages of this document may be reproduced in any form or transmitted by any means without prior permission of ROHM CO.,LTD.
- The contents described herein are subject to change without notice. The specifications for the product described in this document are for reference only. Upon actual use, therefore, please request that specifications to be separately delivered.
- Application circuit diagrams and circuit constants contained herein are shown as examples of standard use and operation. Please pay careful attention to the peripheral conditions when designing circuits and deciding upon circuit constants in the set.
- Any data, including, but not limited to application circuit diagrams information, described herein are intended only as illustrations of such devices and not as the specifications for such devices. ROHM CO.,LTD. disclaims any warranty that any use of such devices shall be free from infringement of any third party's intellectual property rights or other proprietary rights, and further, assumes no liability of whatsoever nature in the event of any such infringement, or arising from or connected with or related to the use of such devices.
- Upon the sale of any such devices, other than for buyer's right to use such devices itself, resell or otherwise dispose of the same, no express or implied right or license to practice or commercially exploit any intellectual property rights or other proprietary rights owned or controlled by
- ROHM CO., LTD. is granted to any such buyer.
- Products listed in this document are no antiradiation design.

The products listed in this document are designed to be used with ordinary electronic equipment or devices (such as audio visual equipment, office-automation equipment, communications devices, electrical appliances and electronic toys).

Should you intend to use these products with equipment or devices which require an extremely high level of reliability and the malfunction of which would directly endanger human life (such as medical instruments, transportation equipment, aerospace machinery, nuclear-reactor controllers, fuel controllers and other safety devices), please be sure to consult with our sales representative in advance.

It is our top priority to supply products with the utmost quality and reliability. However, there is always a chance of failure due to unexpected factors. Therefore, please take into account the derating characteristics and allow for sufficient safety features, such as extra margin, anti-flammability, and fail-safe measures when designing in order to prevent possible accidents that may result in bodily harm or fire caused by component failure. ROHM cannot be held responsible for any damages arising from the use of the products under conditions out of the range of the specifications or due to non-compliance with the NOTES specified in this catalog.

Thank you for your accessing to ROHM product informations.

More detail product informations and catalogs are available, please contact your nearest sales office.

**ROHM** Customer Support System

THE AMERICAS / EUROPE / ASIA / JAPAN



[www.rohm.com](http://www.rohm.com)

Contact us : [webmaster@rohm.co.jp](mailto:webmaster@rohm.co.jp)



## Looking for pricing, stock, or lifecycle information?

Click below to explore more details on WIN SOURCE:

-  [View RPM973-H16E4A](#) on WIN SOURCE
-  [Rohm Semiconductor](#) Information

## Optimize Your Supply Chain with WIN SOURCE Solutions

-  Global Sourcing Solution
-  Obsolete Management
-  Cost Control Management
-  Shortage Management
-  Alternative Solution
-  Excess Inventory Management