



**THE DATASHEET OF
FSA4157P6X**



Low-Voltage, 1 Ω SPDT Analog Switch

FSA4157, FSA4157A

Description

FSA4157 and FSA4157A are high performance Single Pole/Double Throw (SPDT) analog switches. Both devices feature ultra low R_{ON} of 1.15 Ω maximum at 4.5 V V_{CC} and operates over the wide V_{CC} range of 1.65 V to 5.5 V for FSA4157, and 2.7 V to 5.5 V for FSA4157A. The device is fabricated with sub-micron CMOS technology to achieve fast switching speeds and is designed for break-before-make operation. The select input is TTL level compatible.

The FSA4157A features very low quiescent current even when the control voltage is lower than the V_{CC} supply. This feature services the mobile handset applications very well allowing for the direct interface with baseband processor general purpose I/Os.

Features

- FSA4157A Features Lower I_{CC} when the S Input is Lower than V_{CC}
- Maximum 1.15 Ω On Resistance (R_{ON}) at 4.5 V V_{CC}
- 0.3 Ω Maximum R_{ON} Flatness at 4.5 V V_{CC}
- Space-Saving 6-lead, MicroPak™ and SC70 6 Packages
- Broad V_{CC} Operating Range:
 - ◆ FSA4157: 1.65 V to 5.5 V
 - ◆ FSA4157A: 2.7 V to 5.5 V
- Fast Turn-On and Turn-Off Time
- Break-Before-Make Enable Circuitry
- Over-Voltage Tolerant TTL-Compatible Control Circuitry
- These Devices are Pb-Free and are RoHS Compliant



SIP6 1.45X1.0
 CASE 127EB

MARKING DIAGRAMS



- XX = Specific Device Code (EG, EU)
- &K = 2-Digits Lot Run Traceability Code
- &2 = 2-Digit Date Code
- &Z = Assembly Plant Code

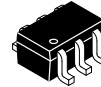

SC-88 (SC-70 6 Lead), 1.25x2
 CASE 419AD

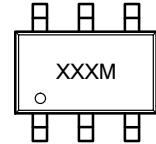

- XXX = Specific Device Code (A57, B57)
- M = Assembly Operation Month

*Date Code orientation and/or position may vary depending upon manufacturing location.

ORDERING INFORMATION

See detailed ordering and shipping information on page 2 of this data sheet.

FSA4157, FSA4157A

ORDERING INFORMATION

Part Number	Top Mark	Package	Shipping†
FSA4157L6X	EG	SIP6 1.45X1.0 (Pb-Free)	5000 / Tape & Reel
FSA4157AL6X	EU	SIP6 1.45X1.0 (Pb-Free)	5000 / Tape & Reel
FSA4157P6X	A57	SC-88 (SC-70 6 Lead), 1.25x2 (Pb-Free)	3000 / Tape & Reel
FSA4157AP6X	B57	SC-88 (SC-70 6 Lead), 1.25x2 (Pb-Free)	3000 / Tape & Reel

†For information on tape and reel specifications, including part orientation and tape sizes, please refer to our Tape and Reel Packaging Specifications Brochure, BRD8011/D.

PIN CONFIGURATIONS

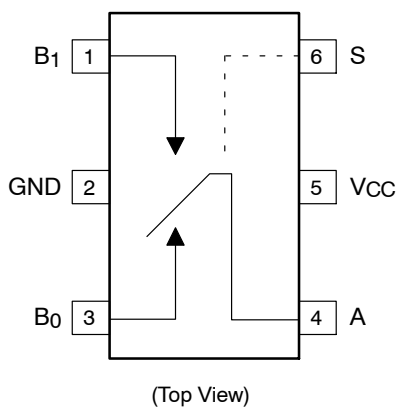

Figure 1. SC70 Pin Assignments

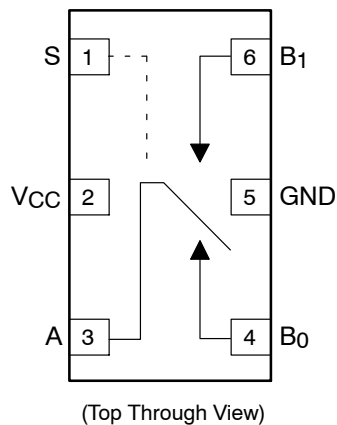

Figure 2. MicroPak Pin Assignments

PIN DEFINITIONS

Pin# SC70	Pin# MicroPak	Name	Description
1	6	B1	Data Ports
2	5	GND	Ground
3	4	B0	Data Ports
4	3	A	Data Ports
5	2	V _{CC}	Supply Voltage
6	1	S	Control Input

TRUTH TABLE

Control Input (S)	Function
Low	B0 connected to A
High	B1 connected to A

FSA4157, FSA4157A

ABSOLUTE MAXIMUM RATINGS

Symbol	Parameter	Min	Max	Unit
V _{CC}	Supply Voltage	-0.5	6.0	V
V _S	DC Switch Voltage (Note 1)	-0.5	V _{CC} + 0.5	V
V _{IN}	DC Input Voltage (Note 1)	-0.5	6.0	V
I _{IK}	DC Input Diode Current	-50		mA
I _{SW}	Switch Current		200	mA
I _{SWPEAK}	Peak Switch Current (Pulse at 1 ms duration, < 10% Duty Cycle)		400	mA
P _D	Power Dissipation at 85°C SC70 MicroPak		180 180	mW
T _{STG}	Storage Temperature Range	-65	+150	°C
T _J	Maximum Junction Temperature		+150	°C
T _L	Lead Temperature (Soldering, 10 seconds)		+260	°C
ESD	Electrostatic Discharge Capability	Human Body Model, JESD22-A114 (FSA4157A)		7500 V

Stresses exceeding those listed in the Maximum Ratings table may damage the device. If any of these limits are exceeded, device functionality should not be assumed, damage may occur and reliability may be affected.

1. Input and output negative ratings may be exceeded if input and output diode current ratings are observed.

RECOMMENDED OPERATING CONDITIONS

Symbol	Parameter	Min	Max	Unit	
V _{CC}	Supply Voltage	FSA4157	1.65	5.50	V
		FSA4157A	2.7	5.5	
V _{CNTRL}	Control Input Voltage (Note 2)	0	V _{CC}	V	
V _{SW}	Switch Input Voltage	0	V _{CC}	V	
T _A	Operating Temperature	-40	+85	°C	
θ _{JA}	Thermal Resistance in Still Air	SC70		350	°C/W
		MicroPak (Estimated)		330	

Functional operation above the stresses listed in the Recommended Operating Ranges is not implied. Extended exposure to stresses beyond the Recommended Operating Ranges limits may affect device reliability.

2. Control input must be held HIGH or LOW and it must not float.

FSA4157, FSA4157A

DC ELECTRICAL CHARACTERISTICS

(Typical values are at 25°C unless otherwise specified.)

Symbol	Parameter	Conditions	V _{CC} (V)	Ambient Temperature					Unit
				-25°C			-40 to +85°C		
				Min.	Typ.	Max.	Min.	Max.	
V _{IH}	Input Voltage High	FSA4157 Only	1.8 to 2.7				1.0		V
			2.7 to 3.6				2.0		
			4.5 to 5.5				2.4		
V _{IL}	Input Voltage Low	FSA4157 Only	1.8 to 2.7					0.4	V
		FSA4157A Only	2.7 to 3.6					0.4	
			2.7 to 3.6					0.6	
			4.5 to 5.5					0.8	
I _{IN}	Control Input Leakage	V _{IN} = 0 V to V _{CC}	2.7 to 3.6				-1.0	1.0	μA
			4.5 to 5.5				-1.0	1.0	
I _{NO(OFF)} , I _{NC(OFF)}	Off Leakage Current of Port B0 and B1	A = 1 V, 4.5 V, B ₀ or B ₁ = 4.5, 1 V	5.5		±2		-20	20	nA
I _{A(ON)}	On Leakage Current of Port A	A = 1 V, 4.5V, B ₀ or B ₁ = 4.5, 1 V, 4.5 V or Floating	5.5		±4		-40	40	nA
R _{ON}	Switch On Resistance	I _{OUT} = 100 mA, B ₀ or B ₁ = 1.5 V	2.7		2.6	4.0		4.3	Ω
		I _{OUT} = 100 mA, B ₀ or B ₁ = 3.5 V	4.5		0.95	1.15		1.30	
ΔR _{ON}	On Resistance Matching Between Channels (Note 4)	I _{OUT} = 100 mA, B ₀ or B ₁ = 1.5 V	4.5		0.06	0.12		0.15	Ω
R _{FLAT(ON)}	On Resistance Flatness (Note 4)	I _{OUT} = 100 mA, B ₀ or B ₁ = 0 V, 0.75 V, 1.5 V	2.7		1.4				Ω
		I _{OUT} = 100 mA, B ₀ or B ₁ = 0 V, 1 V, 2 V	4.5		0.2	0.3		0.4	
I _{CC}	Quiescent Supply Current	V _{IN} = 0 V or V _{CC} , I _{OUT} = 0 V	3.6		0.1	0.5		1.0	μA
			5.5		0.1	0.5		1.0	
ΔI _{CC}	Increase in I _{CC} per Input	One Input at 2.7 V, others at V _{CC} or GND (FSA4157A Only)	4.3		0.2			10.0	μA

3. Measured by the voltage drop between the A and B pins at the indicated current through the switch. On resistance is determined by the lower of the voltage on the two (A or B ports).

4. ΔR_{ON} = R_{ON max} - R_{ON min} measured at identical V_{CC}, temperature, and voltage.

5. Flatness is defined as the difference between the maximum and minimum value of on resistance over the specified range of conditions.

FSA4157, FSA4157A

AC ELECTRICAL CHARACTERISTICS

(Typical values are at 25°C unless otherwise specified.)

Symbol	Parameter	Conditions	V _{CC} (V)	Ambient Temperature					Unit	Figure
				-25°C			-40 to +85°C			
				Min.	Typ.	Max.	Min.	Max.		
t _{ON}	Turn-On Time	B ₀ or B ₁ = 1.5 V, R _L = 50 Ω, C _L = 35 pF (FSA4157A Only)	2.7 to 3.6			60		65	ns	Figure 8
		B ₀ or B ₁ = 1.5V, R _L = 50 Ω, C _L = 35 pF	2.7 to 3.6			50		60		
		B ₀ or B ₁ = 1.5 V, R _L = 50 Ω, C _L = 35 pF	4.5 to 5.5			35		40		
t _{OFF}	Turn-Off Time	B ₀ or B ₁ = 1.5 V, R _L = 50 Ω, C _L = 35 pF	2.7 to 3.6			20		30	ns	Figure 8
		B ₀ or B ₁ = 1.5 V, R _L = 50 Ω, C _L = 35 pF	4.5 to 5.5			15		20		
t _{BBM}	Break-Before-Make Time	FSA4157	2.7 to 3.6						ns	Figure 9
			4.5 to 5.5		20					
		FSA4157A Only	4.5 to 5.5		25					
Q	Charge Injection	C _L = 1.0 nF, V _{GE} = 0 V, R _{GEN} = 0 Ω	2.7 to 3.6		10			pC	Figure 11	
			4.5 to 5.5		20					
OIRR	Off Isolation	f = 1 MHz, R _L = 50 Ω	2.7 to 3.6		-70			dB	Figure 10	
			4.5 to 5.5		-70					
Xtalk	Crosstalk	f = 1 MHz, R _L = 50 Ω	2.7 to 3.6		-70			dB	Figure 10	
			4.5 to 5.5		-70					
BW	-3db Bandwidth	R _L = 50 Ω	2.7 to 3.6			300		MHz	Figure 13	
			4.5 to 5.5			300				
THD	Total Harmon Distortion	R _L = 600 Ω, V _{IN} = 0.5, f = 20 Hz to 20 kHz	2.7 to 3.6		0.002			%	Figure 14	
			4.5 to 5.5		0.002					

CAPACITANCE

Symbol	Parameter	Conditions	V _{CC} (V)	Ambient Temperature -25°C			Units	Figure
				Min.	Typ.	Max.		
C _{IN}	Control Pin Input Capacitance	f = 1 MHz	0.0		3.5		pF	Figure 12
C _{OFF}	B Port Off Capacitance	f = 1 MHz	4.5		12.0		pF	Figure 12
C _{ON}	On Capacitance	f = 1 MHz	4.5		40.0		pF	Figure 12

FSA4157, FSA4157A

TYPICAL PERFORMANCE CHARACTERISTICS

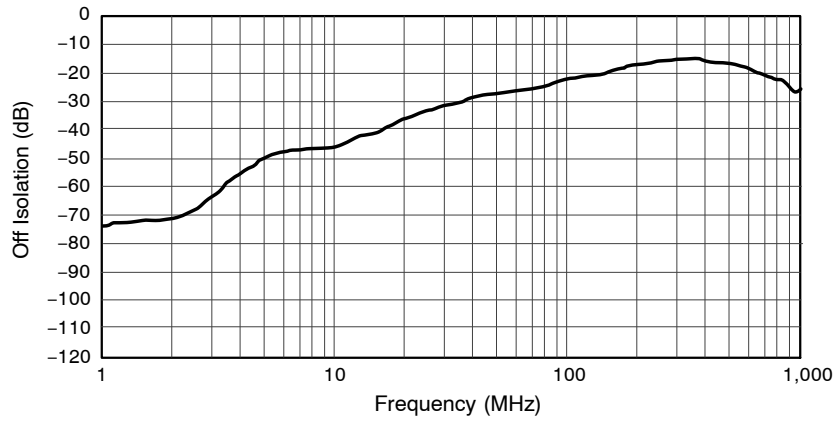

Figure 3. Off Isolation, $V_{CC} = 2.7\text{ V to }5.5\text{ V}$

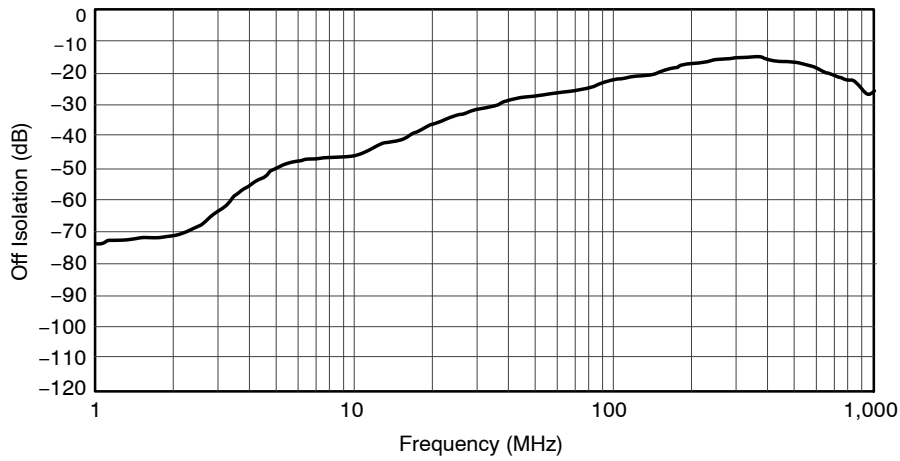

Figure 4. Crosstalk, $V_{CC} = 2.7\text{ V to }5.5\text{ V}$

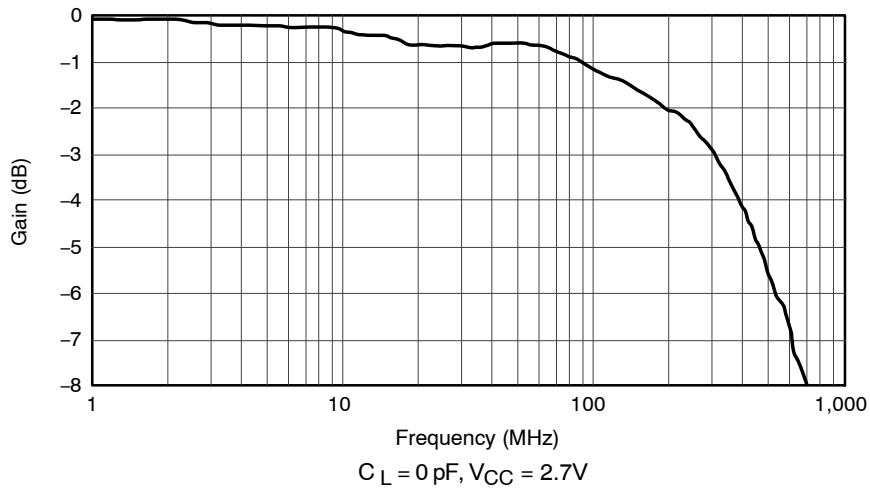

Figure 5. Crosstalk, $V_{CC} = 2.7\text{ V to }5.5\text{ V}$

FSA4157, FSA4157A

TYPICAL PERFORMANCE CHARACTERISTICS (Continued)

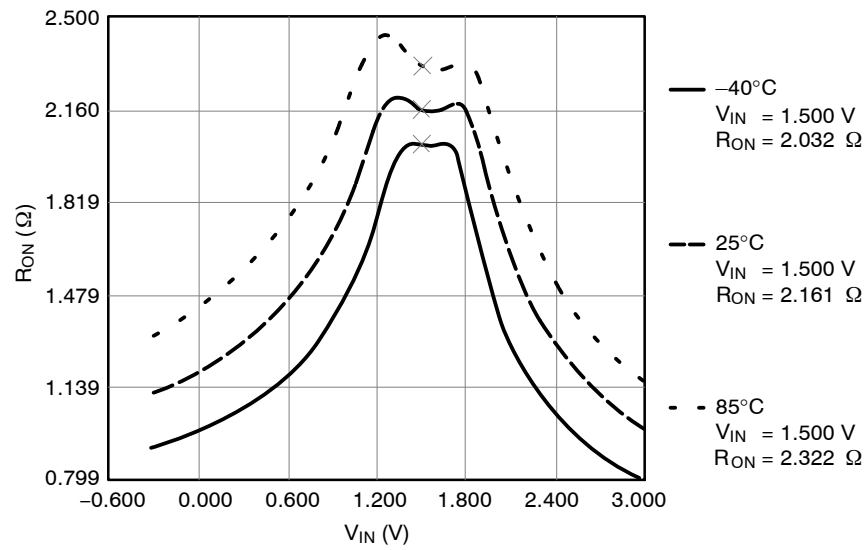

Figure 6. R_{ON} Switch On Resistance, $I_{ON} = 100 \text{ mA}$, $V_{CC} = 2.7 \text{ V}$

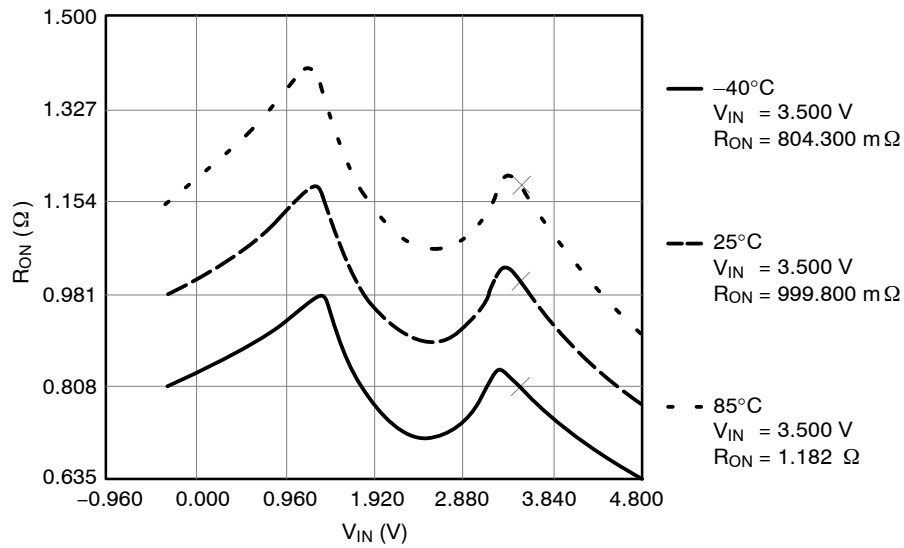

Figure 7. R_{ON} Switch On Resistance, $I_{ON} = 100 \text{ mA}$, $V_{CC} = 4.5 \text{ V}$

FSA4157, FSA4157A

AC LOADINGS AND WAVEFORMS

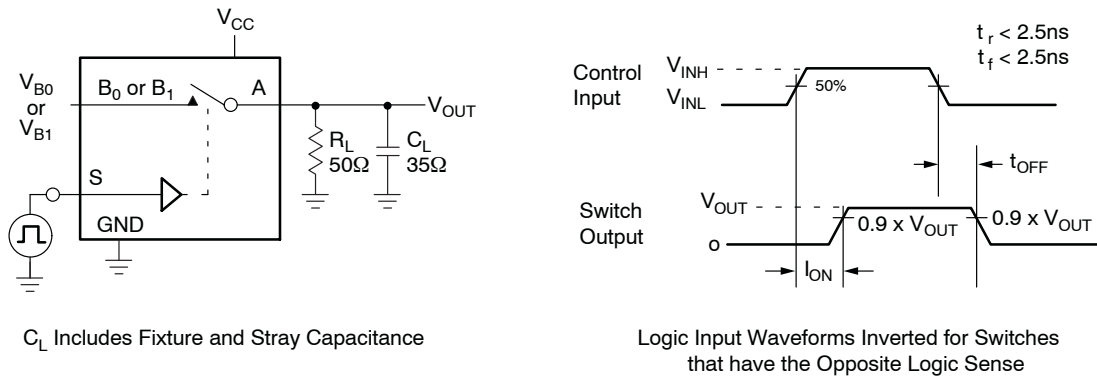

Figure 8. Turn On / Off Timing

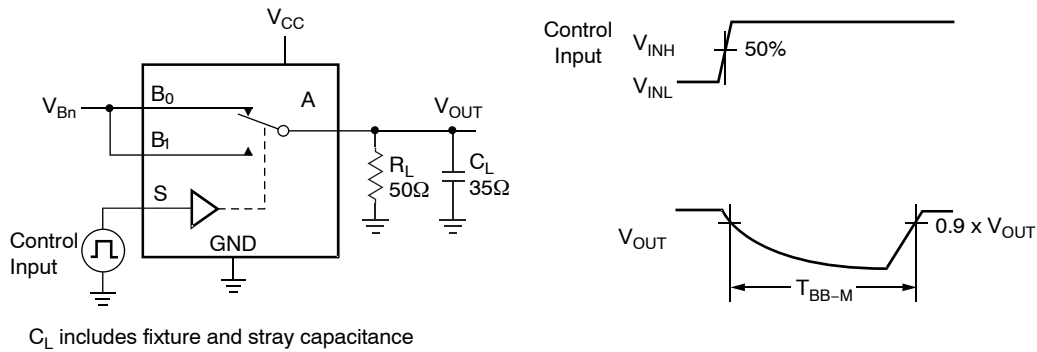

Figure 9. Break Before Make Timing

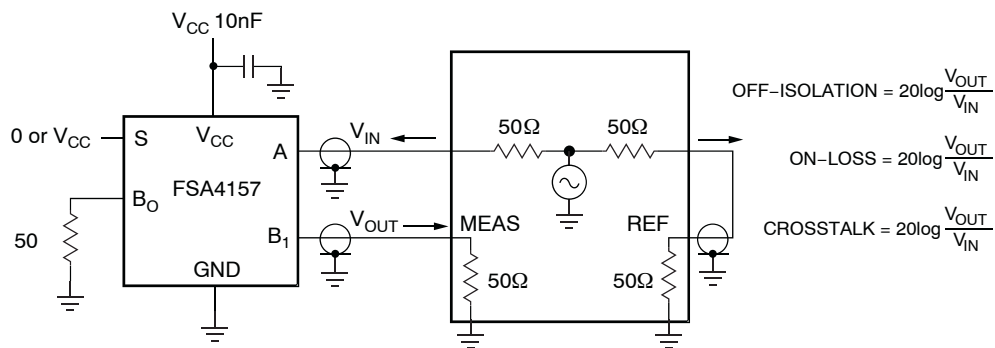

Figure 10. Off Isolation and Crosstalk

FSA4157, FSA4157A

AC LOADINGS AND WAVEFORMS (Continued)

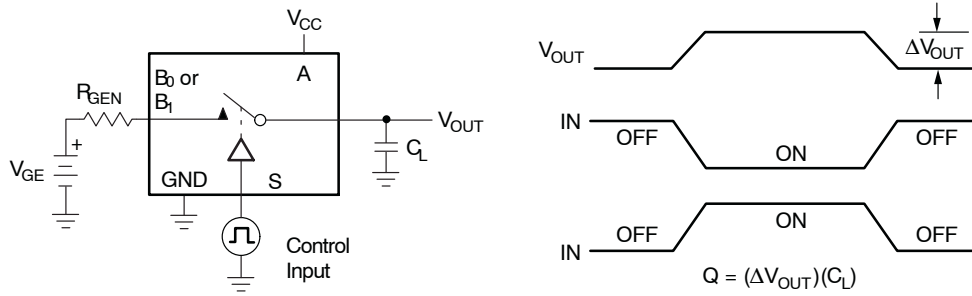

Figure 11. Charge Injection

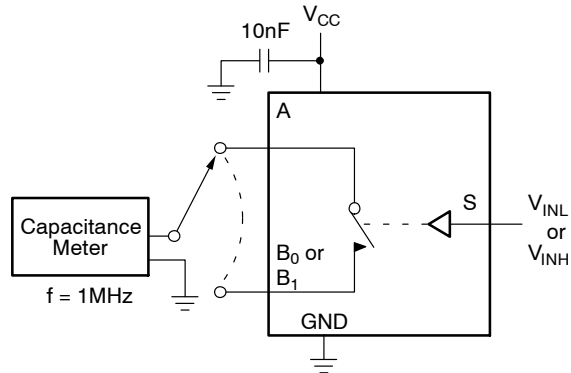

Figure 12. On / Off Capacitance Measurement Setup

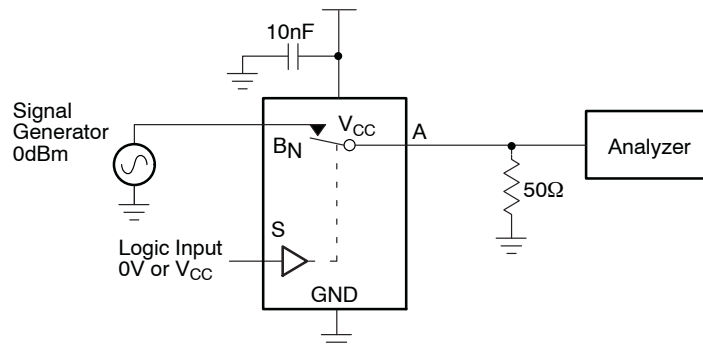

Figure 13. Bandwidth

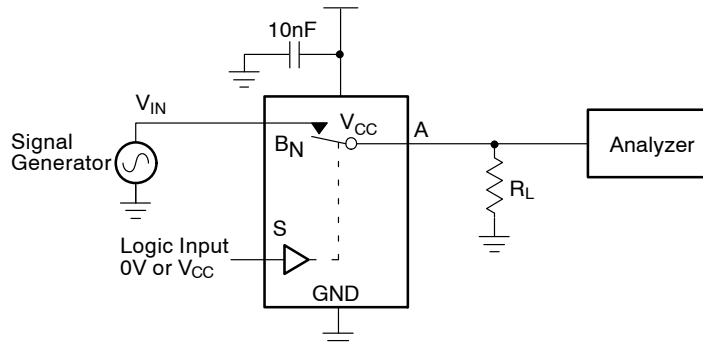
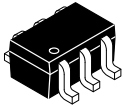

Figure 14. Harmonic Distortion

MicroPak is a trademark of Semiconductor Components Industries, LLC dba "onsemi" or its affiliates and/or subsidiaries in the United States and/or other countries.

MECHANICAL CASE OUTLINE
PACKAGE DIMENSIONS



1

SC-88 (SC-70 6 Lead), 1.25x2
CASE 419AD
ISSUE A

DATE 07 JUL 2010

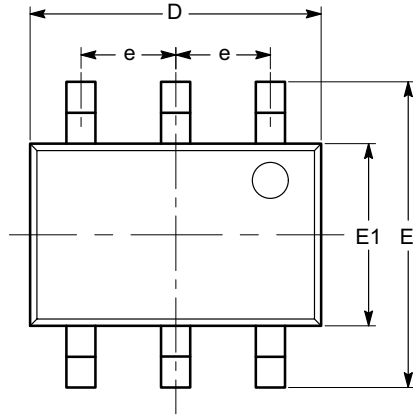

TOP VIEW

SYMBOL	MIN	NOM	MAX
A	0.80		1.10
A1	0.00		0.10
A2	0.80		1.00
b	0.15		0.30
c	0.10		0.18
D	1.80	2.00	2.20
E	1.80	2.10	2.40
E1	1.15	1.25	1.35
e	0.65 BSC		
L	0.26	0.36	0.46
L1	0.42 REF		
L2	0.15 BSC		
θ	0°		8°
θ_1	4°		10°

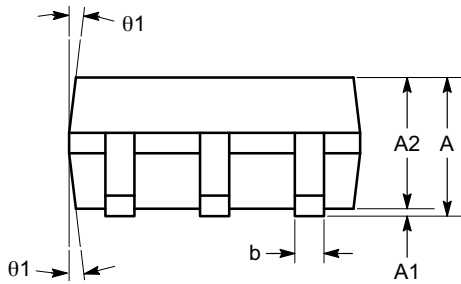

SIDE VIEW

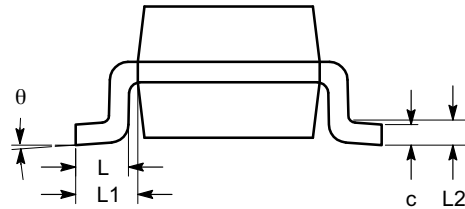

END VIEW

Notes:

- (1) All dimensions are in millimeters. Angles in degrees.
- (2) Complies with JEDEC MO-203.

DOCUMENT NUMBER:	98AON34266E	Electronic versions are uncontrolled except when accessed directly from the Document Repository. Printed versions are uncontrolled except when stamped "CONTROLLED COPY" in red.
DESCRIPTION:	SC-88 (SC-70 6 LEAD), 1.25X2	PAGE 1 OF 1

onsemi and ONSEMI are trademarks of Semiconductor Components Industries, LLC dba onsemi or its subsidiaries in the United States and/or other countries. onsemi reserves the right to make changes without further notice to any products herein. onsemi makes no warranty, representation or guarantee regarding the suitability of its products for any particular purpose, nor does onsemi assume any liability arising out of the application or use of any product or circuit, and specifically disclaims any and all liability, including without limitation special, consequential or incidental damages. onsemi does not convey any license under its patent rights nor the rights of others.

onsemi, **Onsemi**, and other names, marks, and brands are registered and/or common law trademarks of Semiconductor Components Industries, LLC dba "**onsemi**" or its affiliates and/or subsidiaries in the United States and/or other countries. **onsemi** owns the rights to a number of patents, trademarks, copyrights, trade secrets, and other intellectual property. A listing of **onsemi**'s product/patent coverage may be accessed at www.onsemi.com/site/pdf/Patent-Marking.pdf. **onsemi** reserves the right to make changes at any time to any products or information herein, without notice. The information herein is provided "as-is" and **onsemi** makes no warranty, representation or guarantee regarding the accuracy of the information, product features, availability, functionality, or suitability of its products for any particular purpose, nor does **onsemi** assume any liability arising out of the application or use of any product or circuit, and specifically disclaims any and all liability, including without limitation special, consequential or incidental damages. Buyer is responsible for its products and applications using **onsemi** products, including compliance with all laws, regulations and safety requirements or standards, regardless of any support or applications information provided by **onsemi**. "Typical" parameters which may be provided in **onsemi** data sheets and/or specifications can and do vary in different applications and actual performance may vary over time. All operating parameters, including "Typicals" must be validated for each customer application by customer's technical experts. **onsemi** does not convey any license under any of its intellectual property rights nor the rights of others. **onsemi** products are not designed, intended, or authorized for use as a critical component in life support systems or any FDA Class 3 medical devices or medical devices with a same or similar classification in a foreign jurisdiction or any devices intended for implantation in the human body. Should Buyer purchase or use **onsemi** products for any such unintended or unauthorized application, Buyer shall indemnify and hold **onsemi** and its officers, employees, subsidiaries, affiliates, and distributors harmless against all claims, costs, damages, and expenses, and reasonable attorney fees arising out of, directly or indirectly, any claim of personal injury or death associated with such unintended or unauthorized use, even if such claim alleges that **onsemi** was negligent regarding the design or manufacture of the part. **onsemi** is an Equal Opportunity/Affirmative Action Employer. This literature is subject to all applicable copyright laws and is not for resale in any manner.

ADDITIONAL INFORMATION

TECHNICAL PUBLICATIONS:



Technical Library: www.onsemi.com/design/resources/technical-documentation
onsemi Website: www.onsemi.com

ONLINE SUPPORT: www.onsemi.com/support

For additional information, please contact your local Sales Representative at www.onsemi.com/support/sales

Looking for pricing, stock, or lifecycle information?

Click below to explore more details on WIN SOURCE:

-  [View FSA4157P6X on WIN SOURCE](#)
-  [Fairchild/ON Semiconductor](#) Information

Optimize Your Supply Chain with WIN SOURCE Solutions

-  Global Sourcing Solution
-  Obsolete Management
-  Cost Control Management
-  Shortage Management
-  Alternative Solution
-  Excess Inventory Management